

Continuous processes for Fine Chemistry

Julià Sempere, Rosa Nomen
and Eduard Serra

ChemEng

Overview

Motivation (as in 2008!)

Fast development of continuous reactors for Fine Chemistry.

New concept continuous calorimeters.

- ✓ Reaction calorimeter + tubular reactor.
- ✓ Reaction calorimeter + continuous stirred tank reactor.
- ✓ Homemade very small oscillation reaction calorimeter.

Design concepts for continuous separations.

ChemEng

Now, we have nice plants for Fine Chemicals

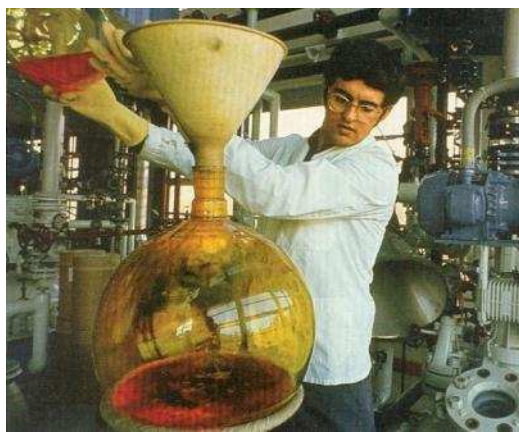

The “organic chemist” concept:
Lab → Kilolab → Pilot plant → Production plant



Result: Fine Chemicals' plants
are nice emulations
of lab scale reactors



emEng

This philosophy has consequences.



Kilolab, Spain, 2006



Kanawha Valley,
 USA, 2008



SURVIVRE A SEVESO?



la popolazione di Seveso
 esso la ditta ICMSA di Meda, in provincia di Milano, si verificò una
 classico contenente diossina. Fu necessario ordinare la temporanea
 popolazione di Seveso, un centro situato nei pressi degli stabilimenti.

Seveso,
 Italy, 1976

Excellent and didactical examples of runaway events

Chemical Safety Board:

www.csb.gov



On December 19, 2007, four people were killed and 13 others were transported to the hospital when an explosion occurred at T2 Laboratories Inc.

Who audited the Seveso accident?



Paolo Cardillo

Direttore de la Stazione Sperimentale per i Combustibili
San Donato Milanese (Italy)

One of the **HarsNet** initiators

www.harsnet.net

ChemEng

The major cause of runaway accidents: lack of knowledge!



A very, very ancient conviction:

P. F. Nolan and J. A. Barton, Some lessons from thermal-runaway incidents,
Journal of Hazardous Materials, **1987**, 14(2):233-239.

P. Cardillo, *Incidenti in ambiente chimico - Guida allo studio e alla valutazione delle reazioni fuggitive*, Stazione sperimentale per i Combustibili, San Donato Milanese, **1998**.

ChemEng

Nolan and Barton, 1989

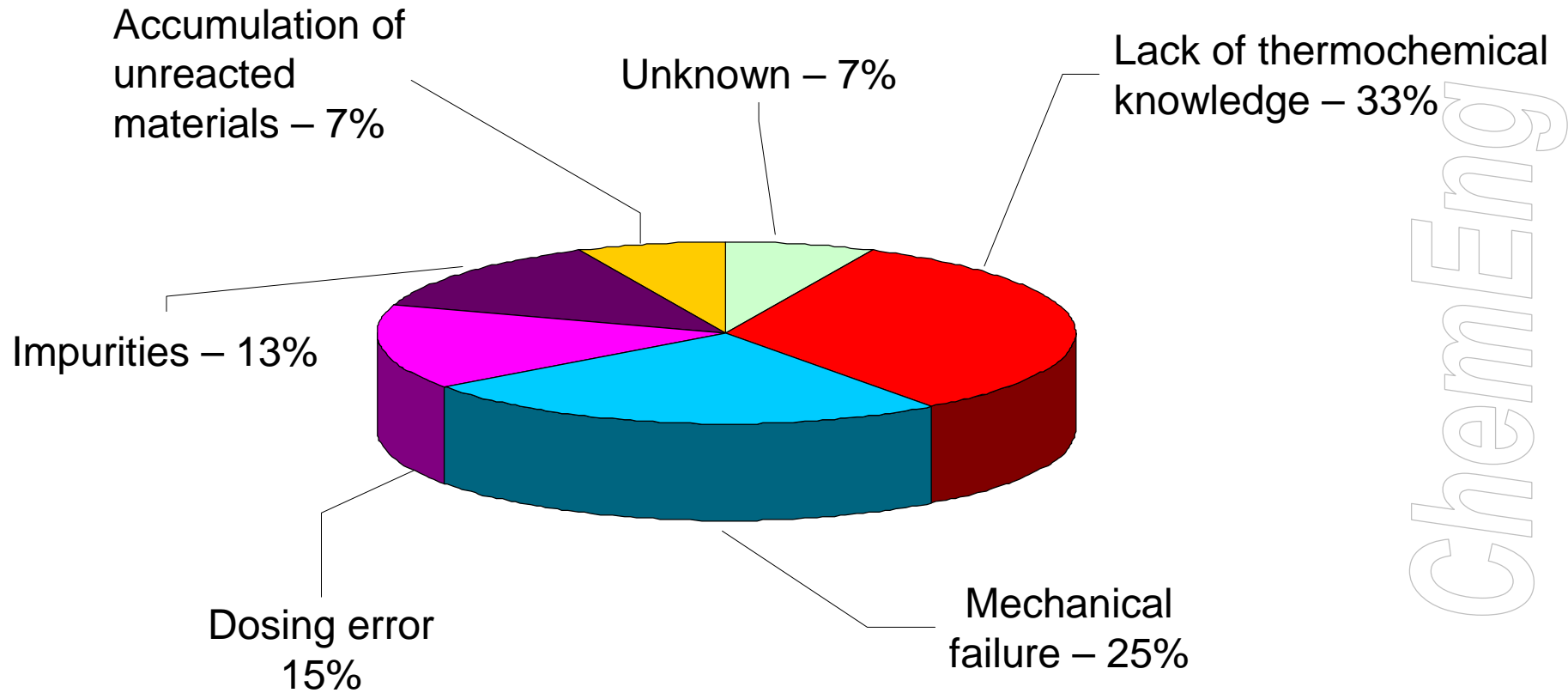

ChemEng

Lack of thermochemical knowledge

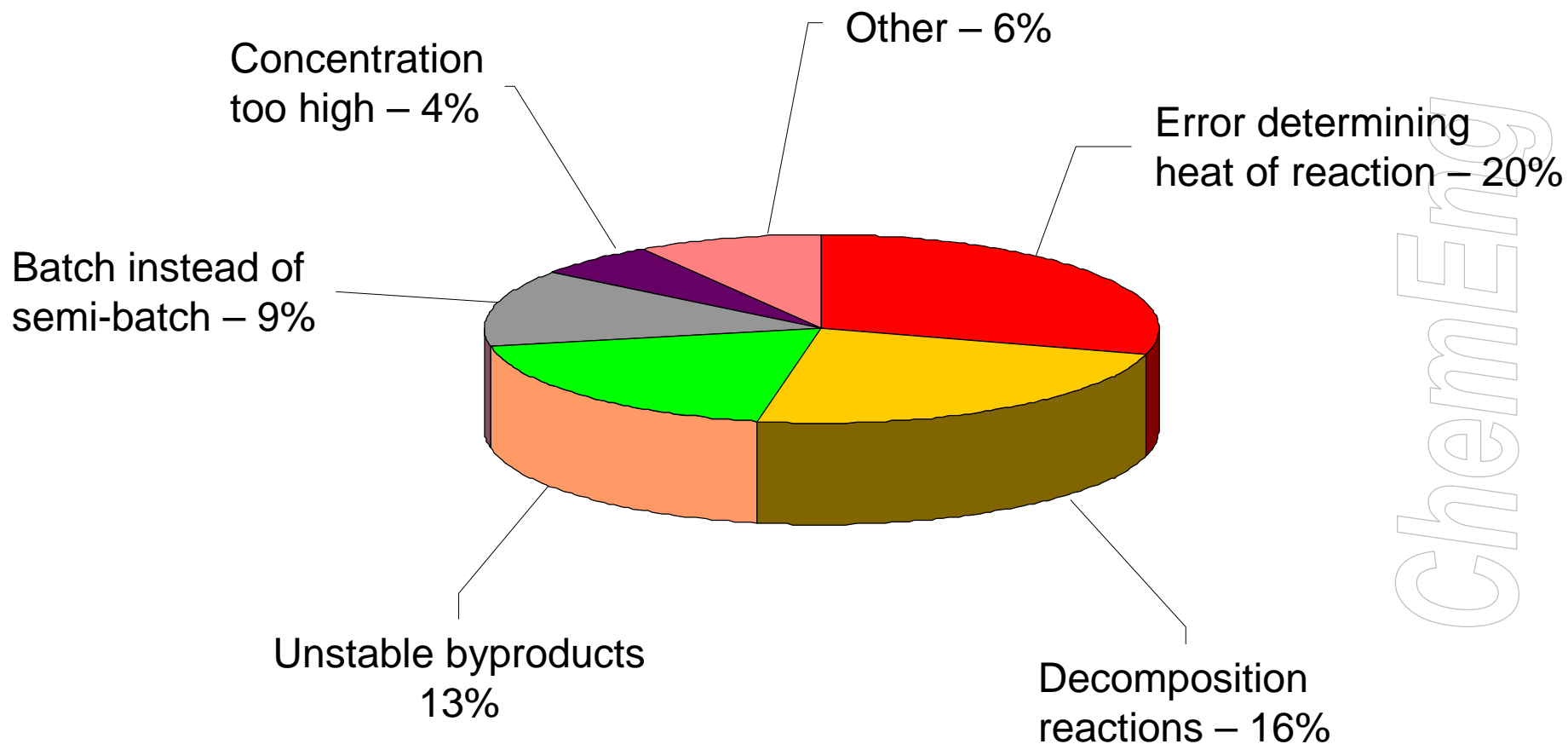

ChemEng

Determination of Heat of Reaction



Lavoisier - Laplace

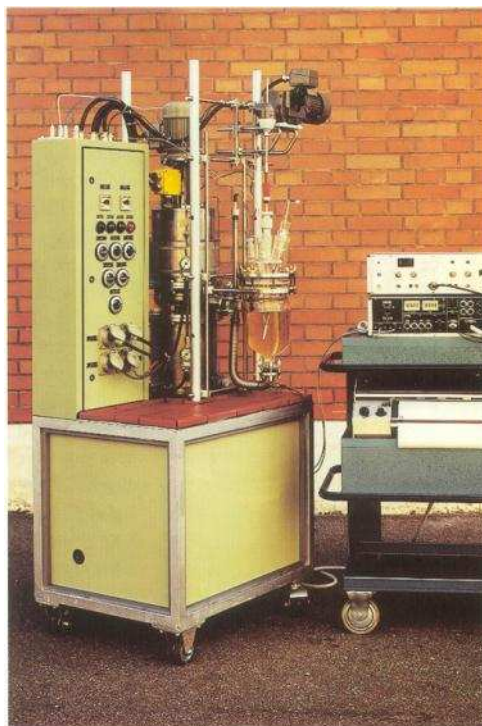

Regenass' WFK75
Ciba-Geigy



Mettler -Toledo RC1®

**R50 and RC1[®] at or group.
The very beginning at IQS**



ChemEng

Runaway prevention

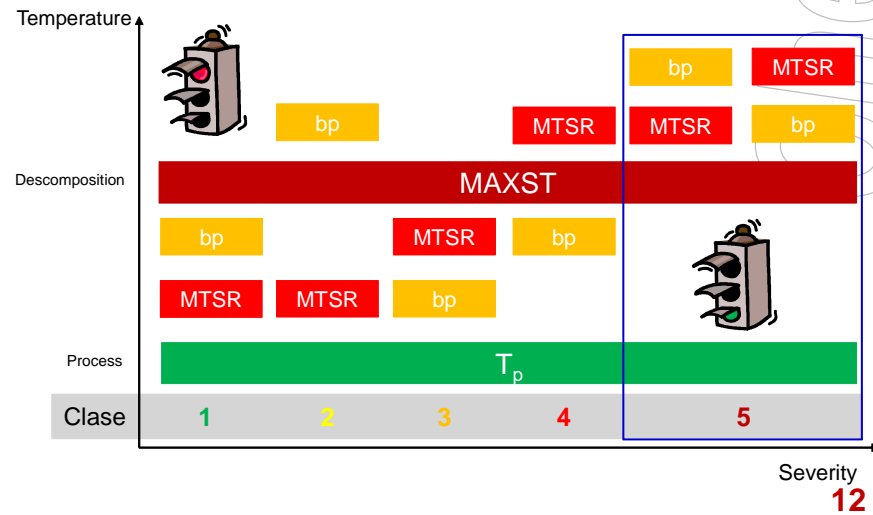
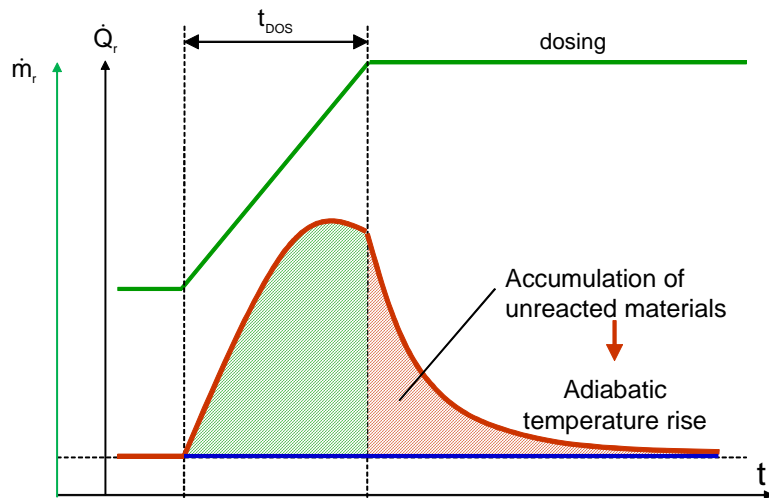
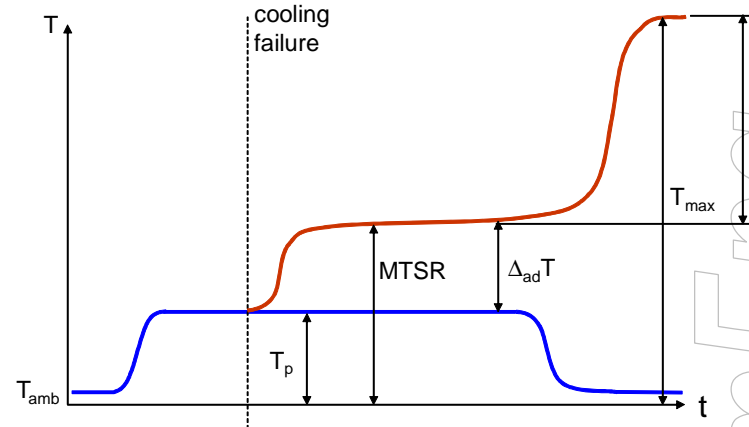
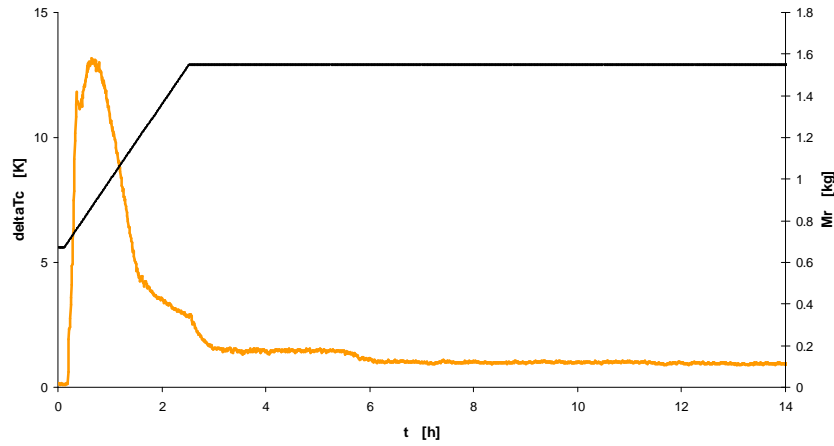

Three quotations from Albert Einstein

Insanity: doing the same thing over and over again
and expecting different results.

We cannot solve our problems with the same thinking
we used when we created them.

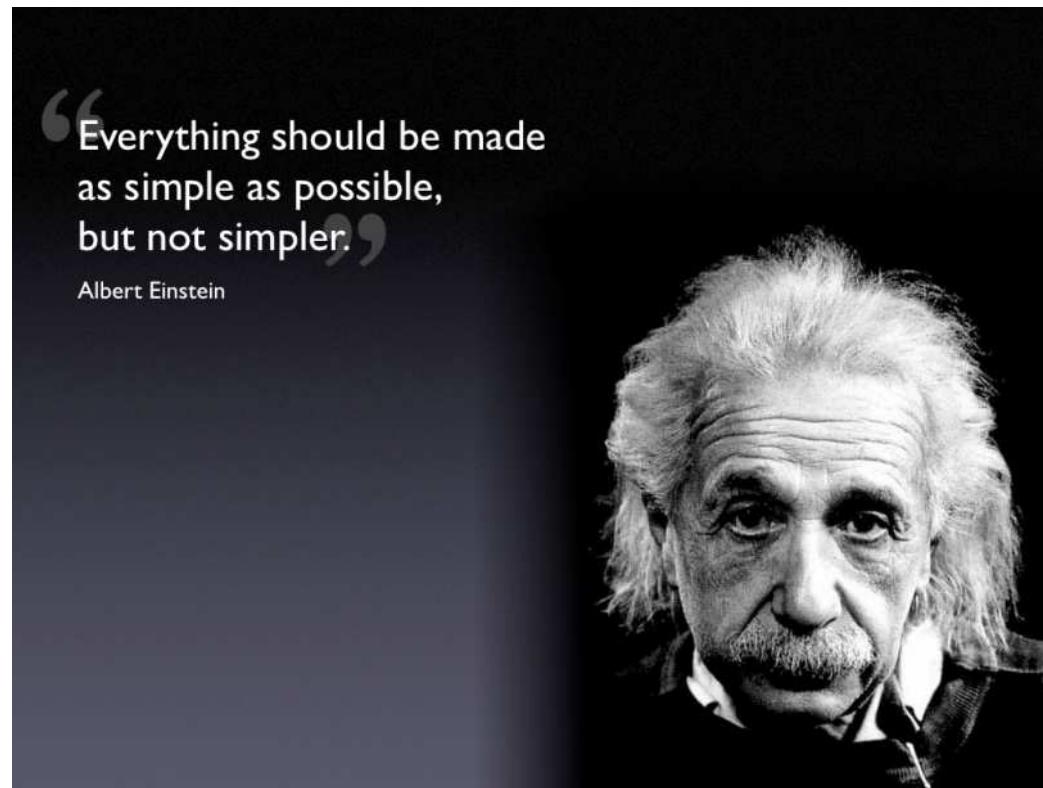

A general principle

T. Kletz. *An engineer's view of human error*. IChemE. Rugby 2001

Try to change situations, not people

*Here, as engineers,
we are not concerned with the reasons
why these errors – slips and lapses of attention – occur,
but with the fact that they do occur
and that we can do little to prevent them.*

We should therefore accept them and design accordingly.

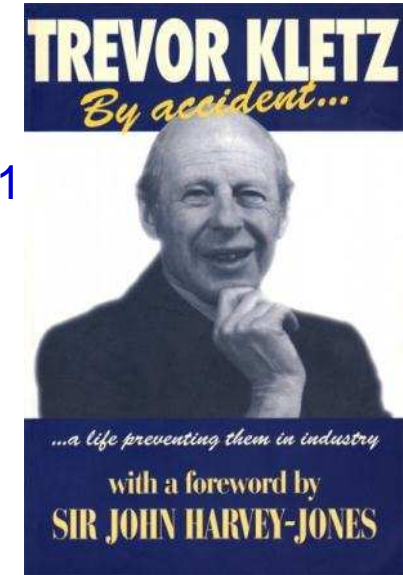

ChE

Issues in Fine Chemical's current technology

Safety:

- ✓ Big amounts of reactive chemicals put all together to react.
- ✓ Accumulation of unreacted materials, ...

Quality:

- ✓ Strong human intervention in processes.
Some estimations indicate that 25% of batches has almost one loading error (most of them with no major consequences).

Environment:

- ✓ Difficulty for recycling raw materials.

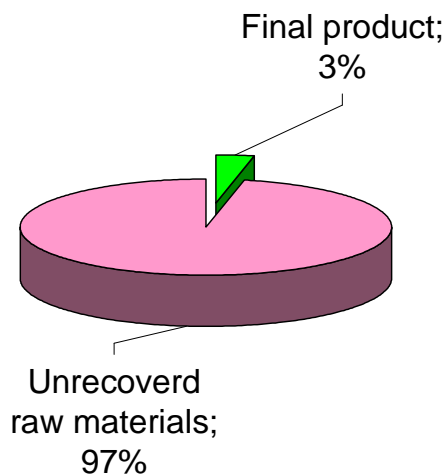

Why not using traditional engineering approaches?

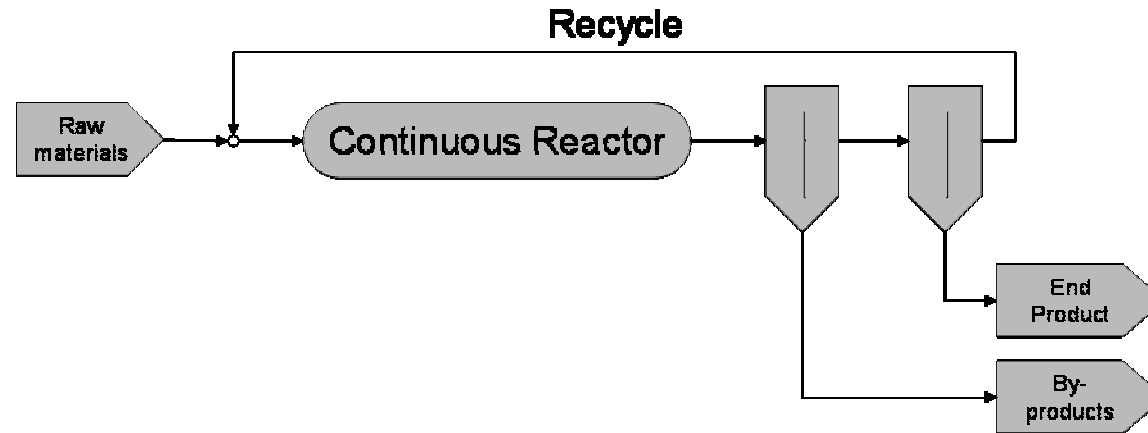

Cost and time of development?

Long start-up and shut-down operations generating wastes?

Out of production philosophy of Fine Chemicals producers?

ChemEng

Continuous processes

Small reactors

- ✓ Small quantities of hazardous materials → SAFETY

Zero waste (near 1% in process industries)

- ✓ Recycles.
- ✓ By-products valorisation.

} → ENVIRONMENT

Automated

- ✓ Few human intervention → QUALITY + SAFETY

Challenges in Fine Chemicals' continuous production

Fast development tools.

Separation operations.

ChemEng

RC1® + PFR

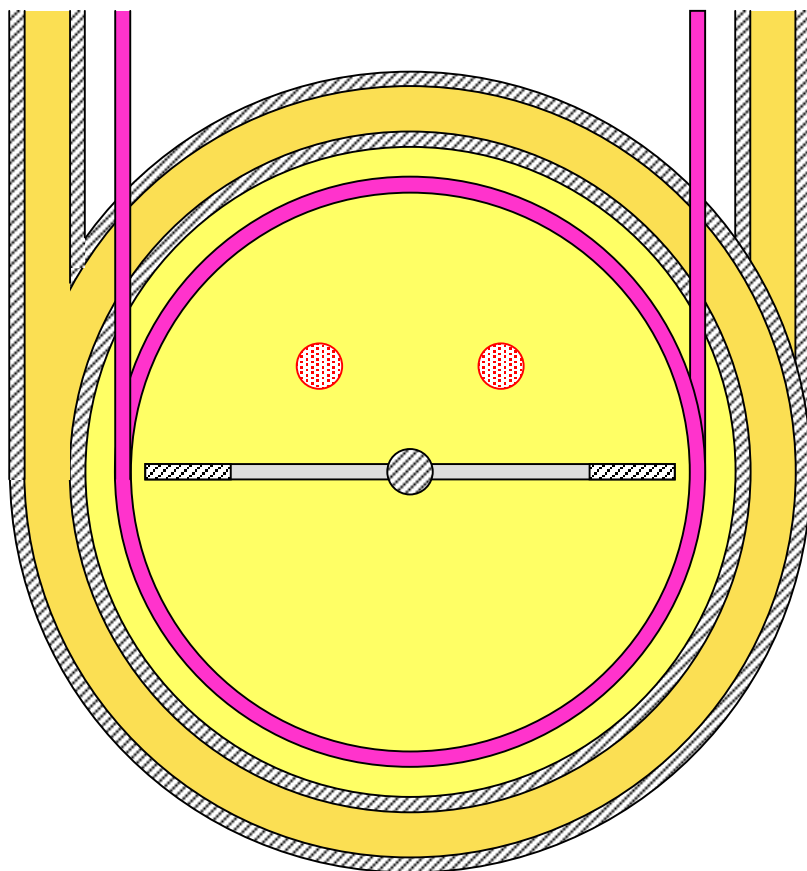

Volume: 0.050 L
Material: PTFE



Results of PFR calorimeter Punctual heat of reaction (not measured)

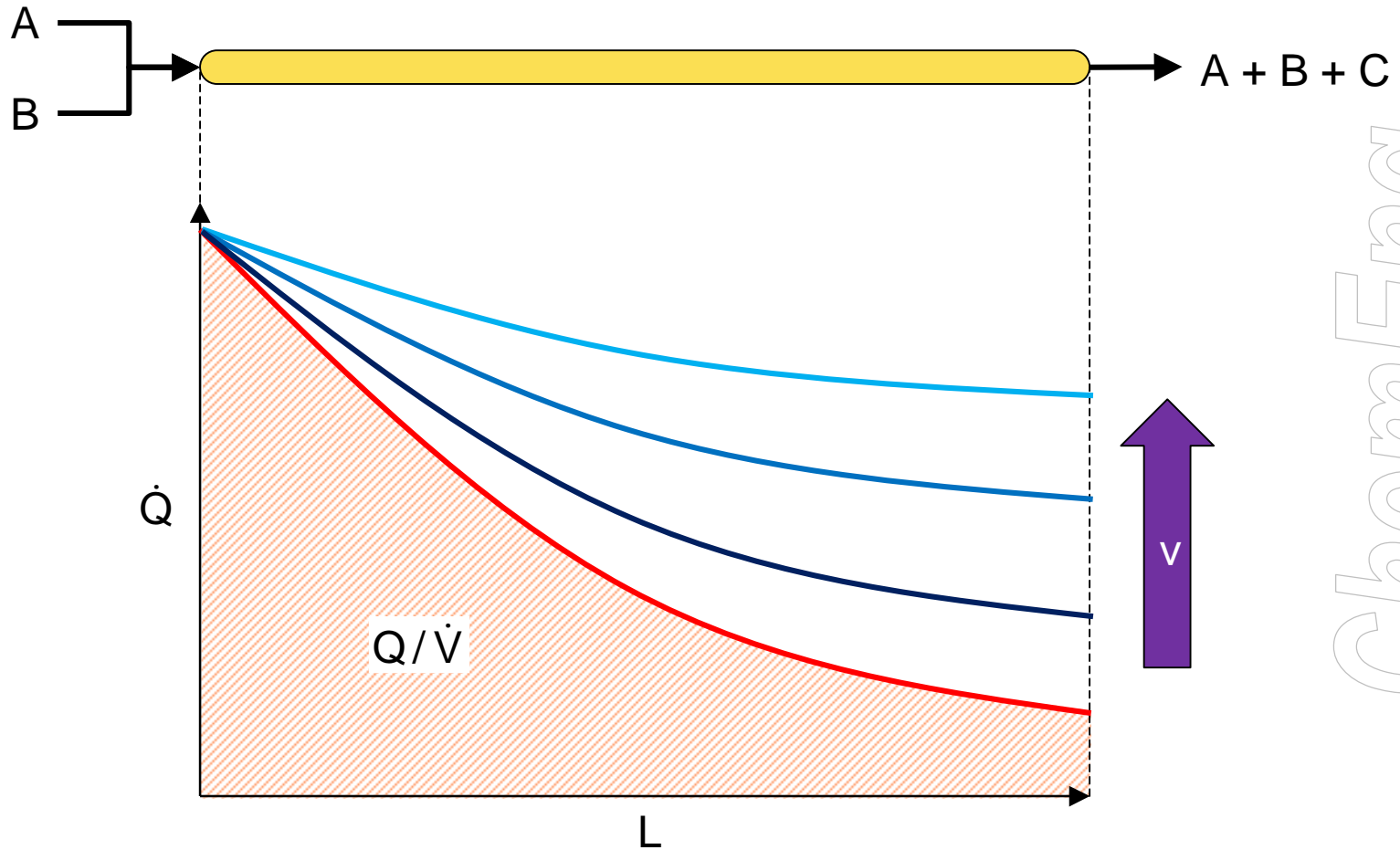

ChemEng

Results of PFR calorimeter Total heat of reaction vs. velocity

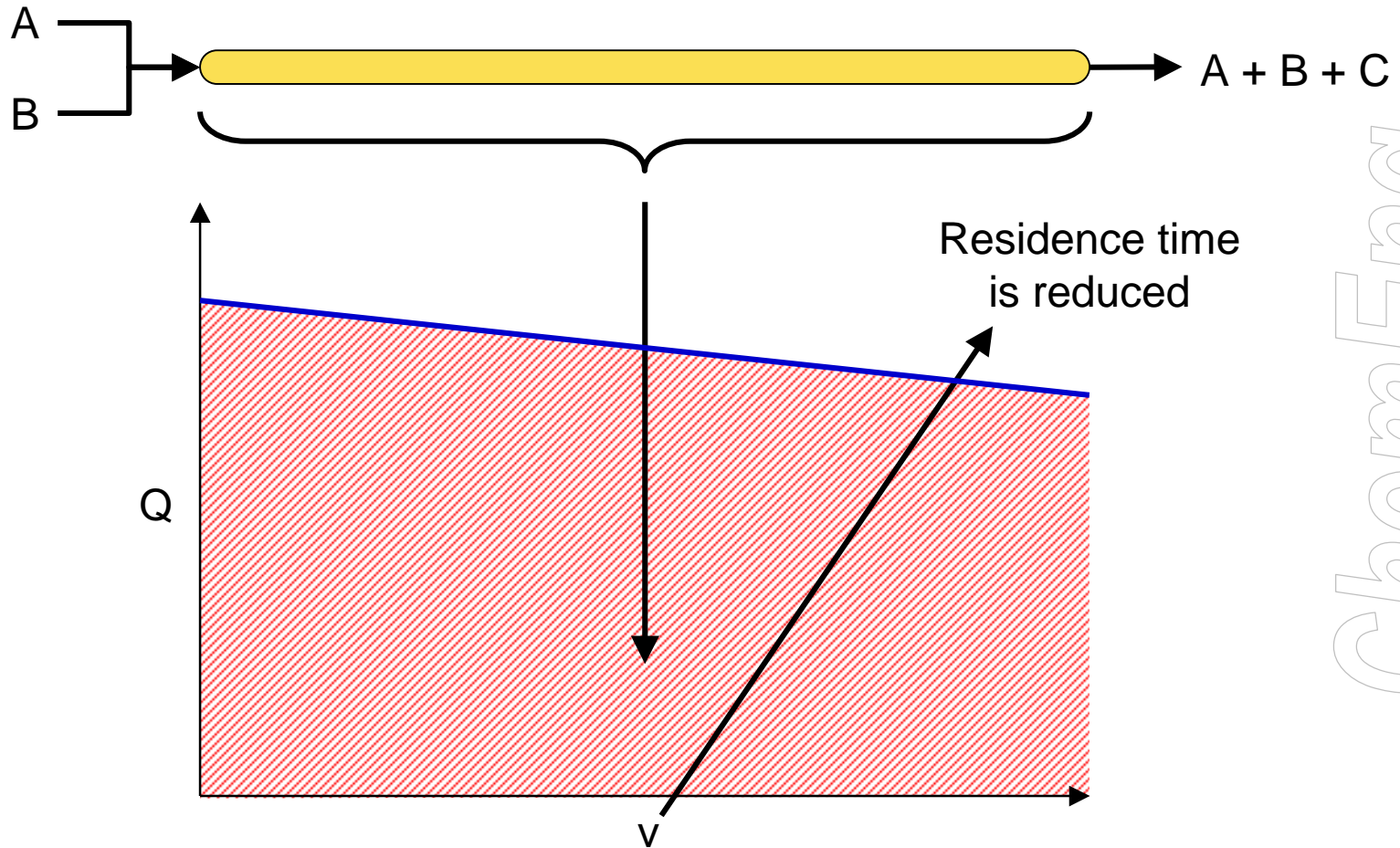

ChemEng

Weak kinetic information

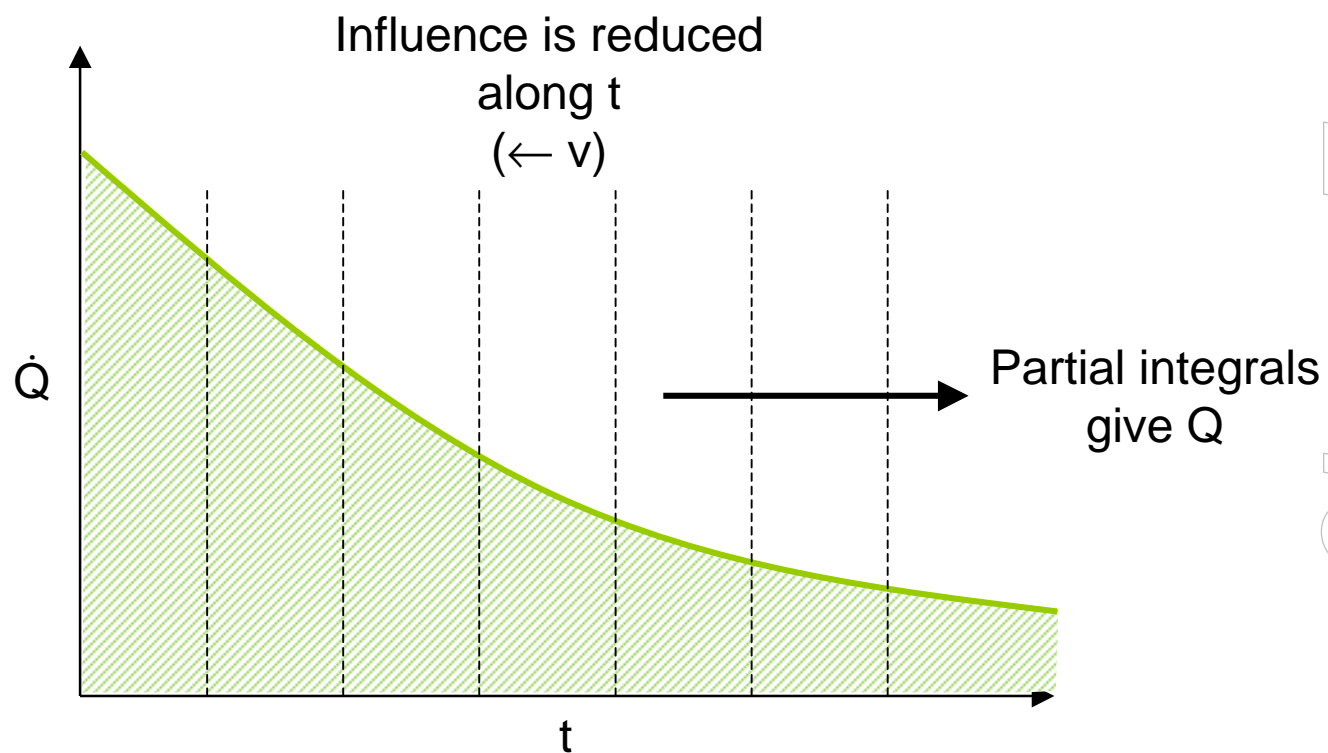

ChemEng



PERSONA CIENCIA EMPRESA
Universitat Ramon Llull



Volume: 0.100 - 0.500 L
Material: Glass

RC1[®] + PFR

Small commercial RC1[®] reactors
could be used.

However,

- ✓ Accurate level control is not solved yet.
- ✓ Number of connections is not enough, usually.
- ✓ Some bottom connections should be required.

A new reactor has been designed
and operated.

ChemEng

The MCC Magic Cube Calorimeter

Low mass block calorimeter

- ✓ No heavy / insulating wall.
- ✓ U-A reduced to hi-A
- ✓ Reduced time constant.
- ✓ Programmed temperature.

Power oscillation

- ✓ On-line U-A and Cp.

In improvement

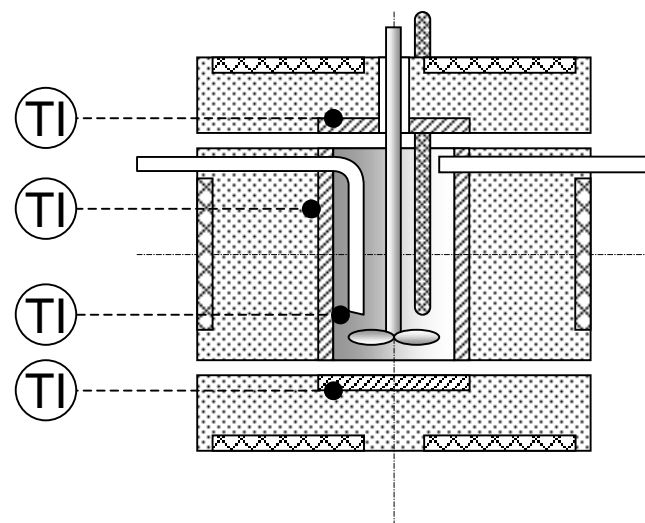

ChemEng

MCC at work

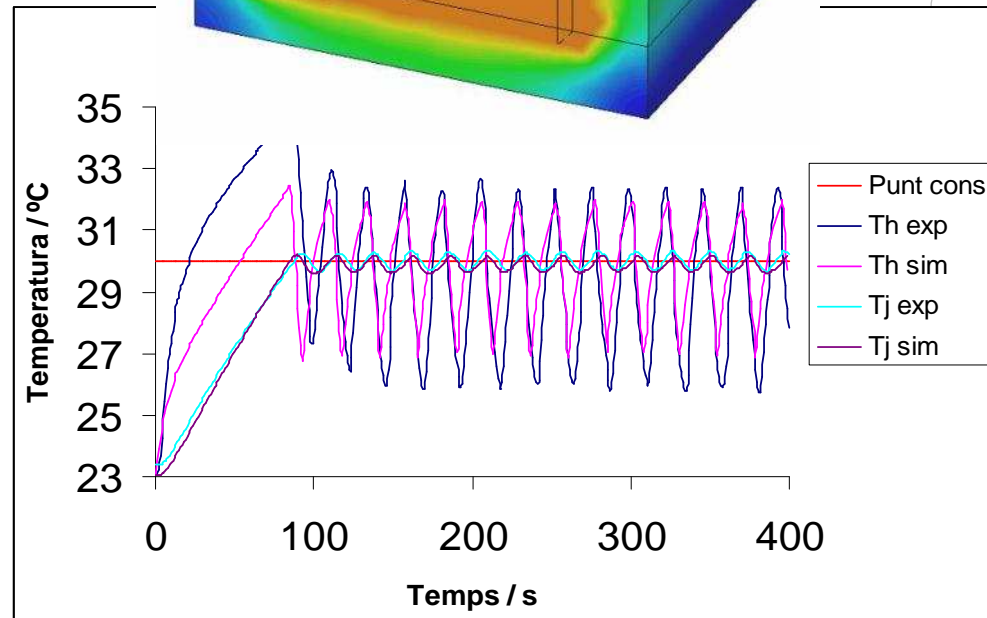
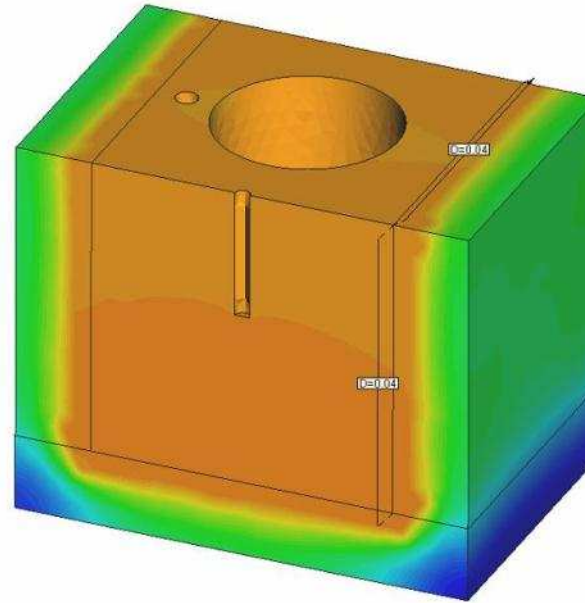
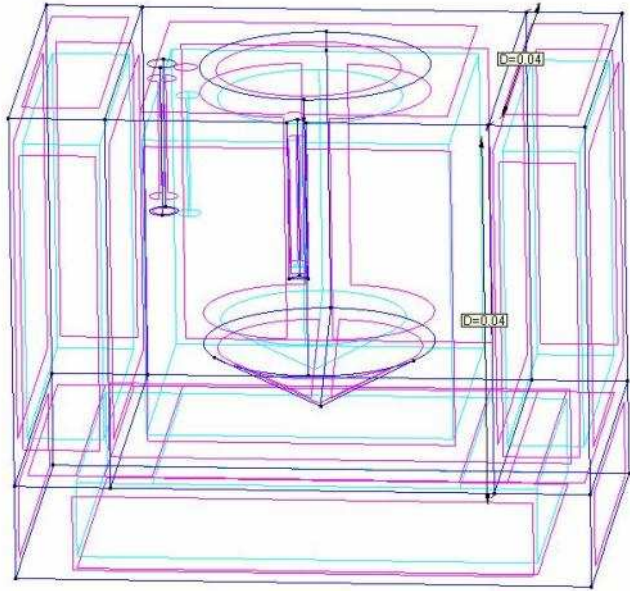

Mettler Toledo RTCaTM

"A nice dream for continuous calorimetry"

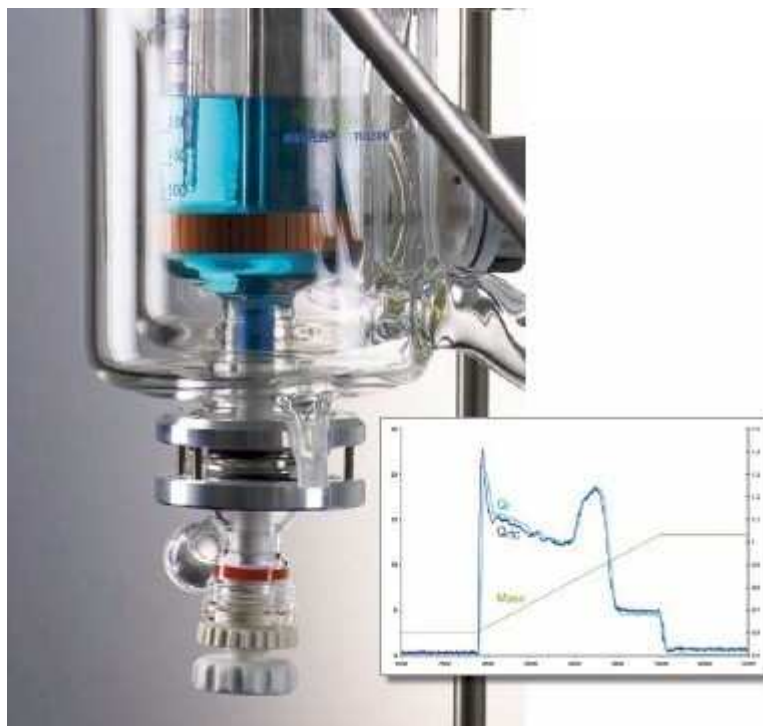

ChemEng



Results

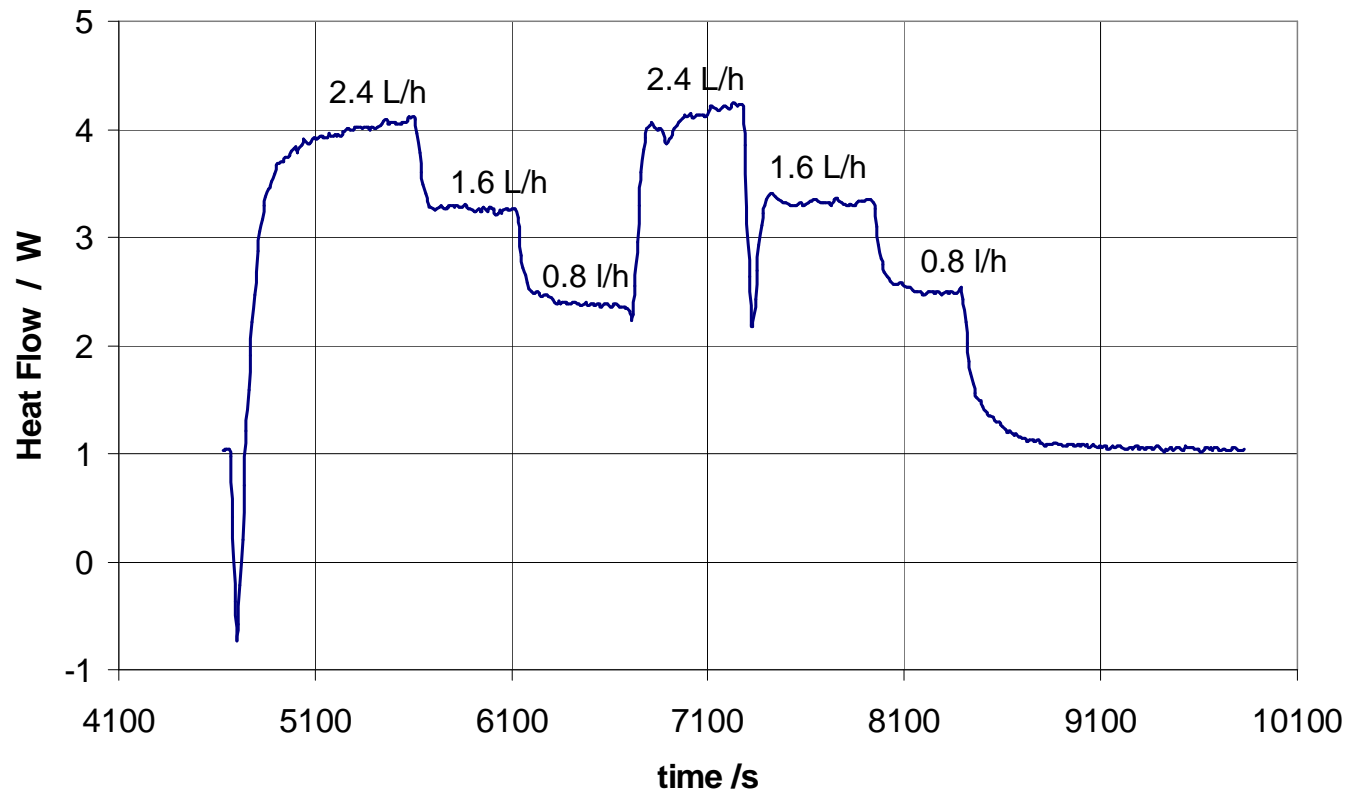
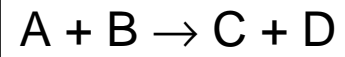

ChemEng

Direct measurement of “reaction rate”

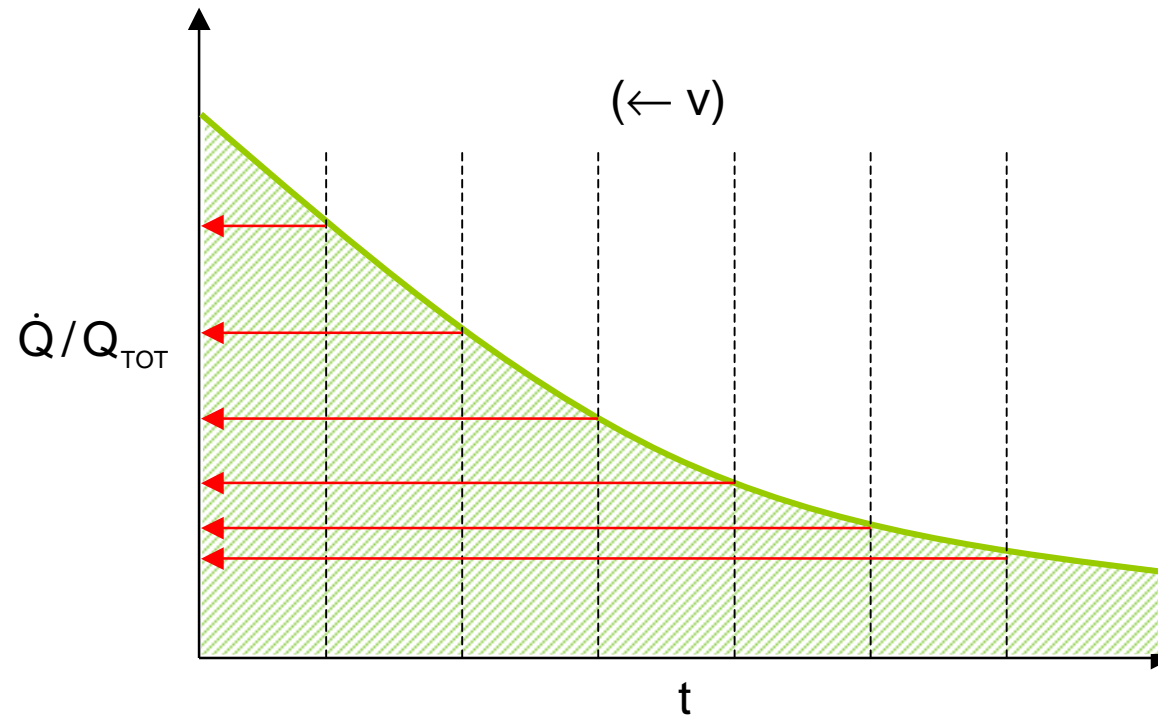
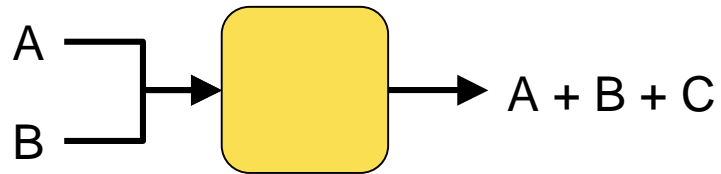

ChemEng

PFR and CSTR

A tubular reactor (PFR) can ...

- ✓ be designed for very high pressures.
- ✓ use multiple dosing at different lengths.

Usually Fine Chemicals' processes involve solids

- ✓ PFR is not suitable for transporting solids.
- ✓ Static bed catalytic processes are one exception.

More than one liquid phase could be involved

- ✓ Mixing in a PFR can be achieved using static mixers.
- ✓ However, high velocity of fluids is required.
- ✓ Residence time will be dramatically reduced.
- ✓ Unacceptable long reactors will be necessary.

Gases (evolved or consumed) might be present

- ✓ Only big tubular reactors can cope with this situation.
- ✓ Big PFR are not in the focus.

Checking out

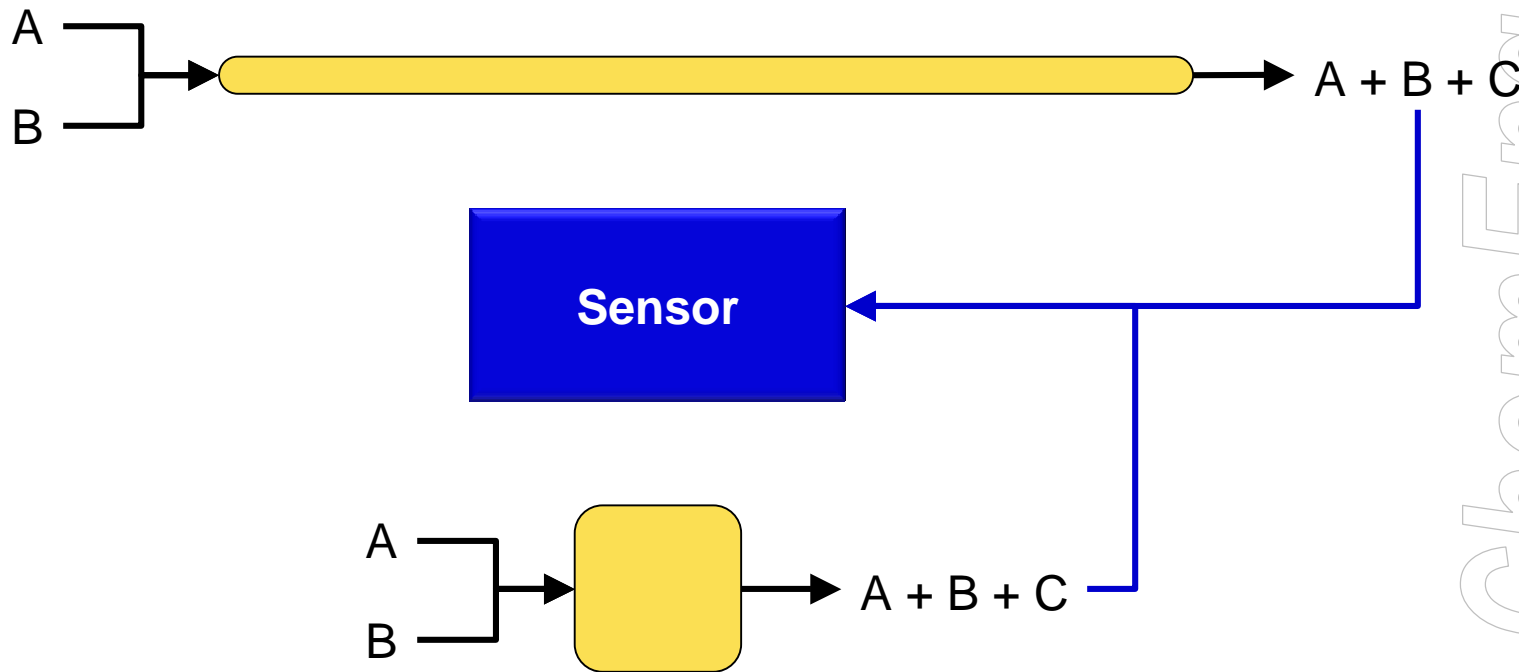

ChemEng

Next step

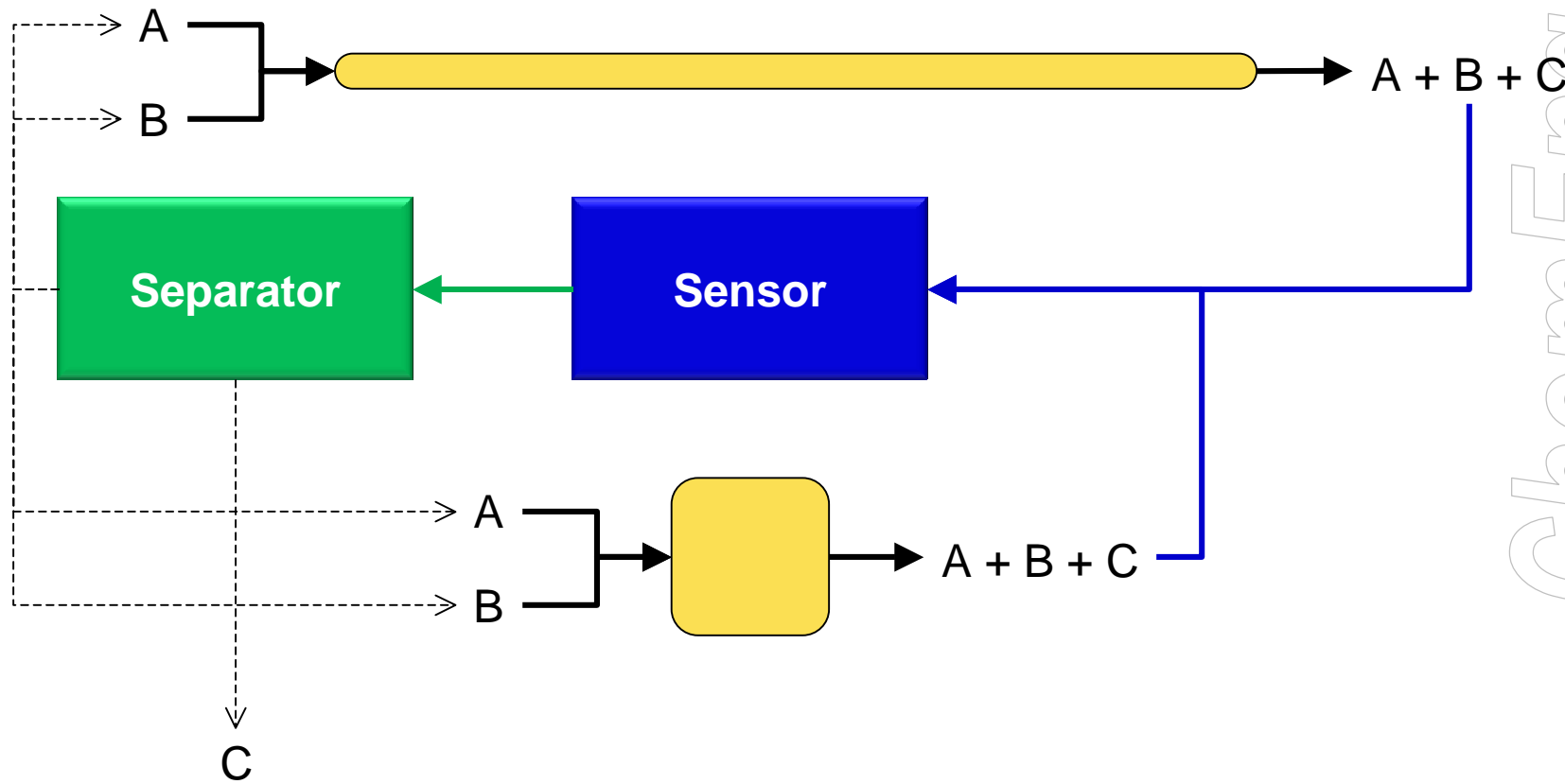

ChemEng

Some strategies for separation processes: SMB

J. Sempere, R. Nomen, E. Serra, O. Pou, S. Martínez, and J. Menacho,
Prototype for the rapid design of continuous adsorbers, CHISA2010 – ECCE7, Prague 2010.

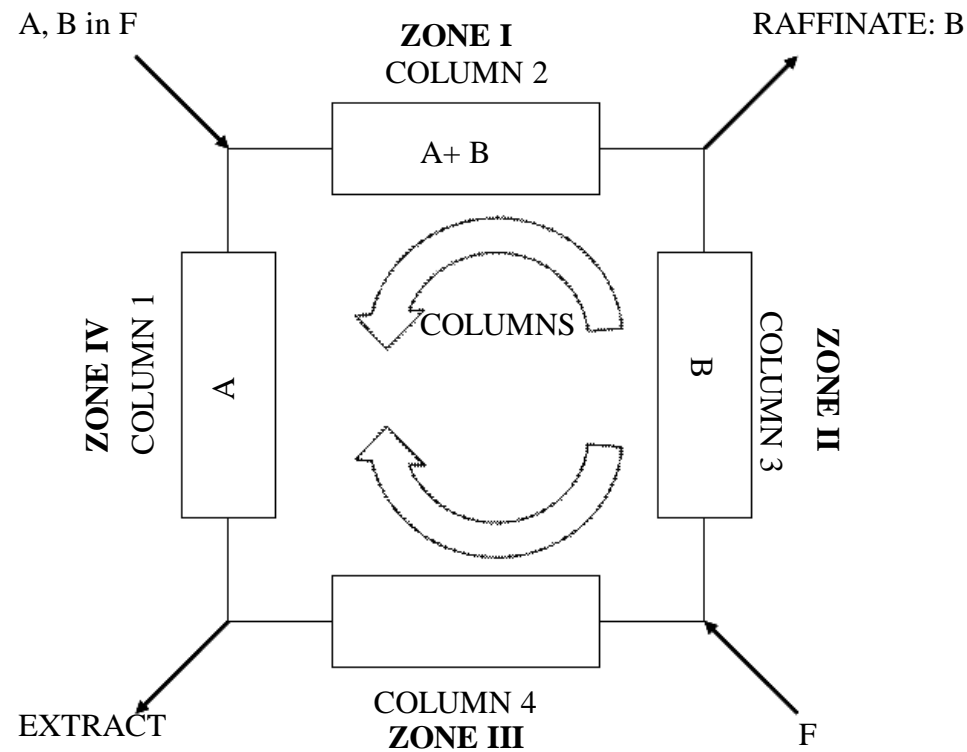

Some strategies for separation processes: **MCSGP**

M. Sans, *MCSGP Process with membrane adsorbers*, TFC, IQS 2008.

Aumann, L.; **Morbidelli**, M.: *A Continuous Multicolumn Countercurrent Solvent Gradient Purification (MCSGP) process*. *Biotechnology and Bioengineering*
DOI 10.1002/bit. 21525, 2007.

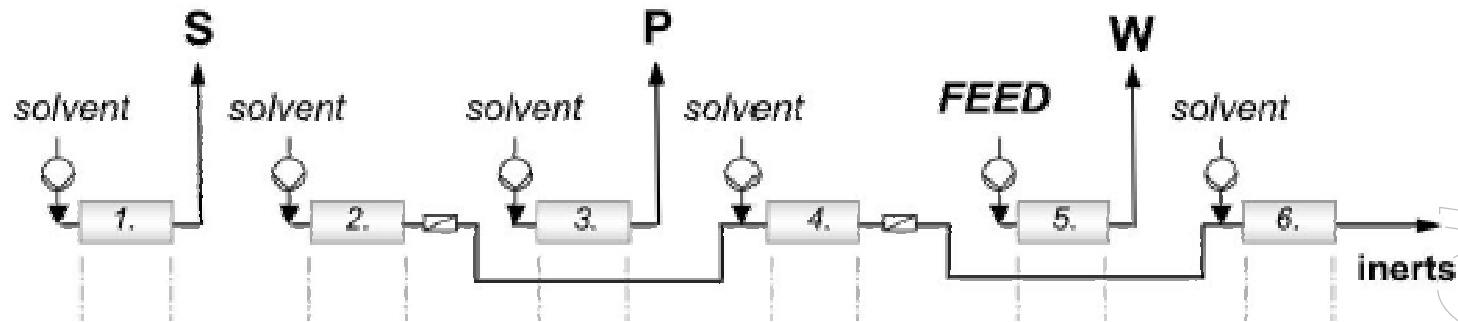

Conclusions

Moving from traditional batch processes for producing Fine Chemicals to continuous processes offers big opportunities:

- ✓ Reducing thermal risks.
- ✓ Improving environmental behaviour.
- ✓ Increasing quality.

Versions of a tubular reactor (PFR) and of a continuous stirred tank reactor (CSTR) coupled to RC1[®] have been developed and checked out.

Both systems can be used for the fast development of industrial continuous reactors.

Strategies for separation of reactor outcomes are being tested.

The whole system reactor – separator will be ready to use in near future to be applied to the fast development of industrial processes.

ChemEng

Prospection of future

A first experiment: the **MCPFC** project.

MULTIPURPOSE CONTINUOUS PROCESSES FOR FINE CHEMICALS

- ✓ 4 companies (2 Spanish, 1 Italian and 1 English).
- ✓ 2 research centers:
 - ✓ Stazione Sperimentale per i Combustibili.
 - ✓ IQS.
- ✓ Submitted to the CAPACITIES EU Program.
- ✓ Not accepted by a *short grading gap*.

New project in preparation.

Acknowledgement

This project is possible thanks to the financial support of the Spanish Ministry of Innovation and Technology, project CTQ2005-01174.

We'd like to acknowledge the work of all our group participating in this task of the project:

- ✓ Dr. E. Serra
- ✓ O. Gomà-Camps
- ✓ J. Gras
- ✓ S. Martínez
- ✓ K. Cuevas
- ✓ M. Grillo
- ✓ O. Pou
- ✓ J. Olivares
- ✓ M. Mallafré
- ✓ ...

ChemEng



PERSONA CIÈNCIA EMPRESA

Universitat Ramon Llull

Via Augusta, 390. 08017 Barcelona (Spain)

julia.sempere@iqs.url.edu

rosa.nomen@iqs.url.edu

eduard.serra@iqs.url.edu

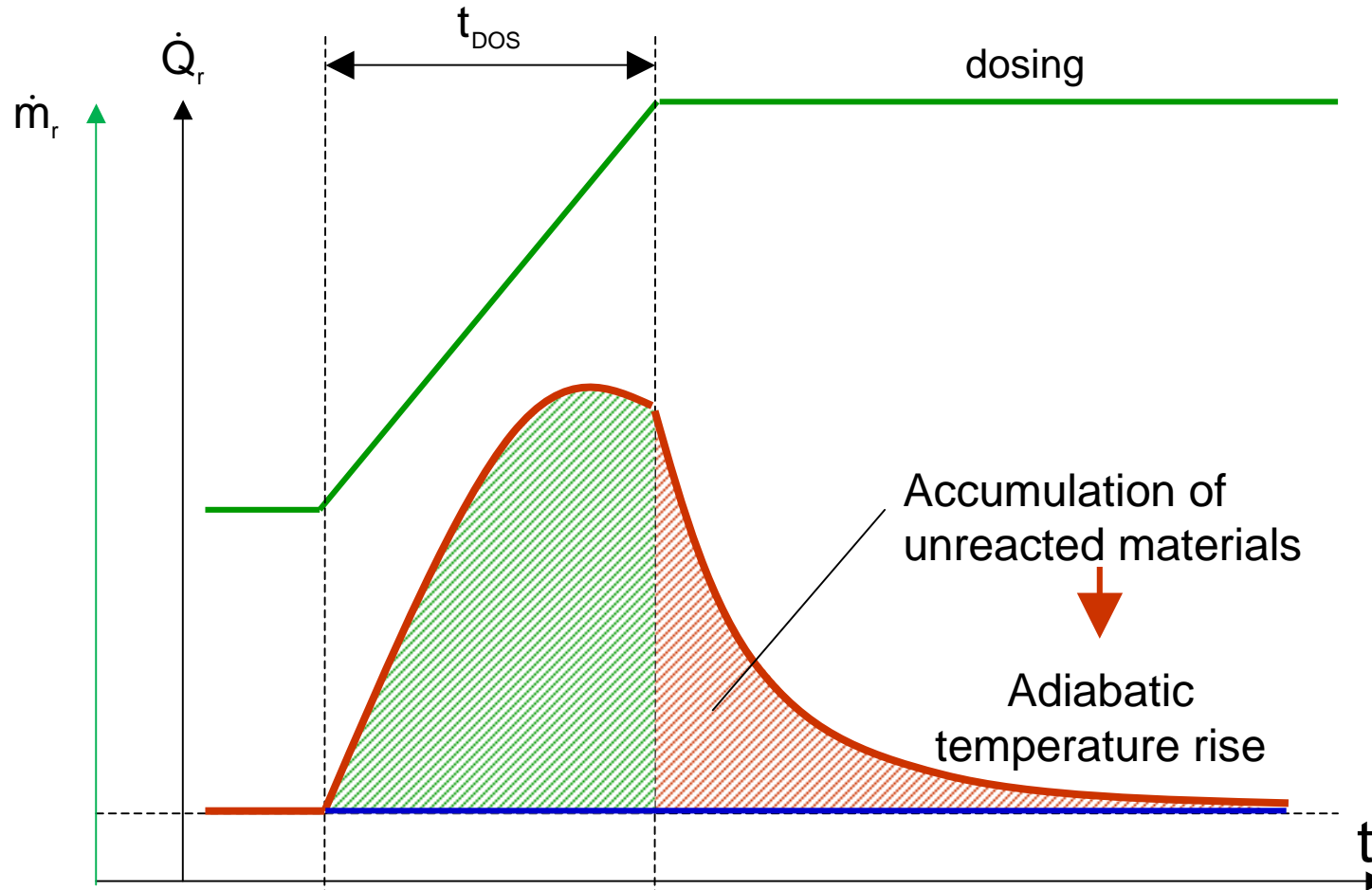

ChemEng

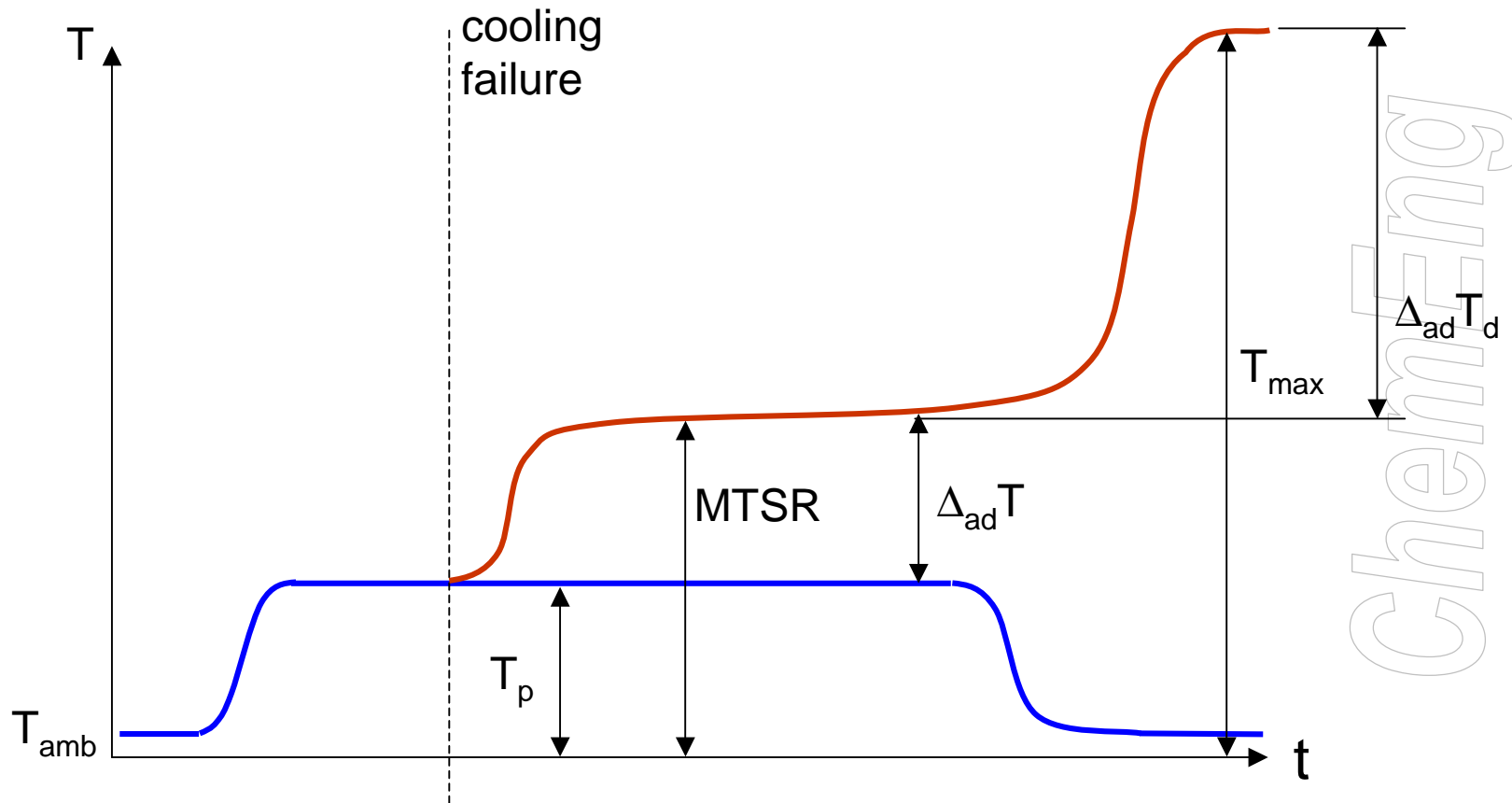

ChemEng

