



PERSPECTIVES FOR THE USAGE OF SECONDARY FUELS IN ITALY

G. Migliavacca, F. Hugony, M. Priola, F. Chiesa

Stazione Sperimentale per i Combustibili

San Donato Milanese - ITALY



Summary

Survey of the Italian waste production and management

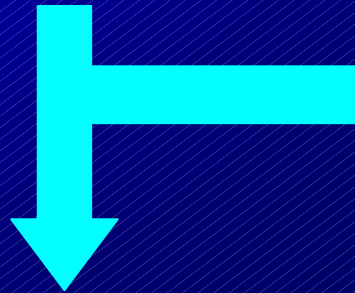

SSC database of fuels properties

Contribution of secondary fuels to the energy system

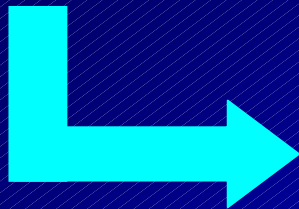

Present situation and future perspectives



EU trend in waste management

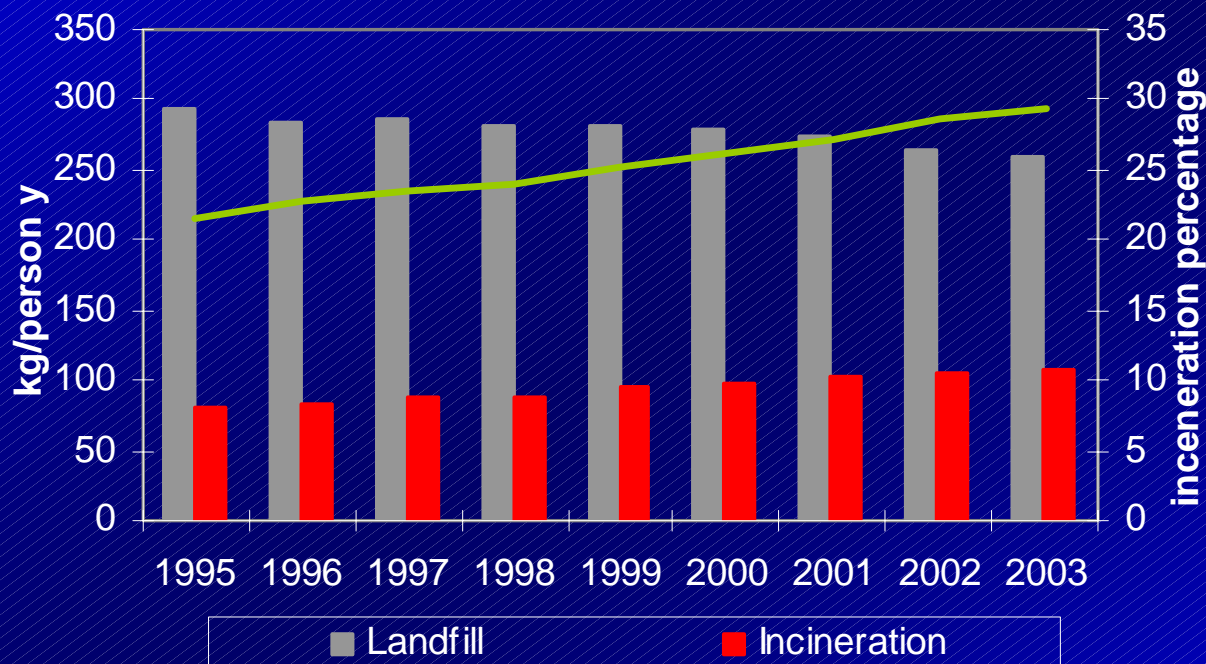

APAT, ONR (2005), "Rapporto Rifiuti 2005"

- Reduction of direct landfill disposal
- Increasing energy recovery



Example of fuels from wastes

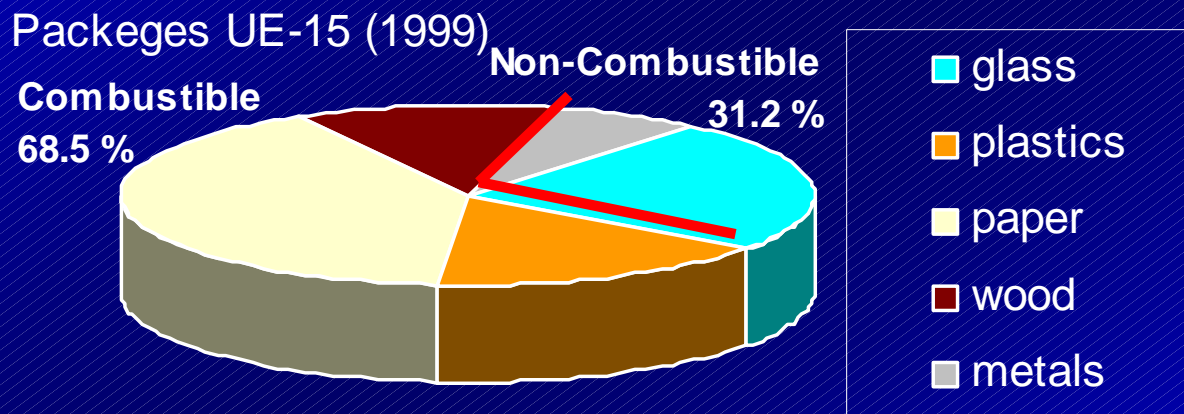

APAT, ONR (2005), "Rapporto Rifiuti 2005"

- High combustible fraction
- Huge energy content

Waste management paths

INDUSTRIAL PRODUCTION

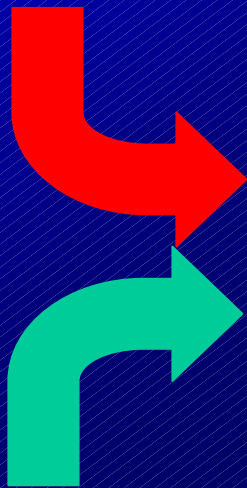

URBAN PRODUCTION

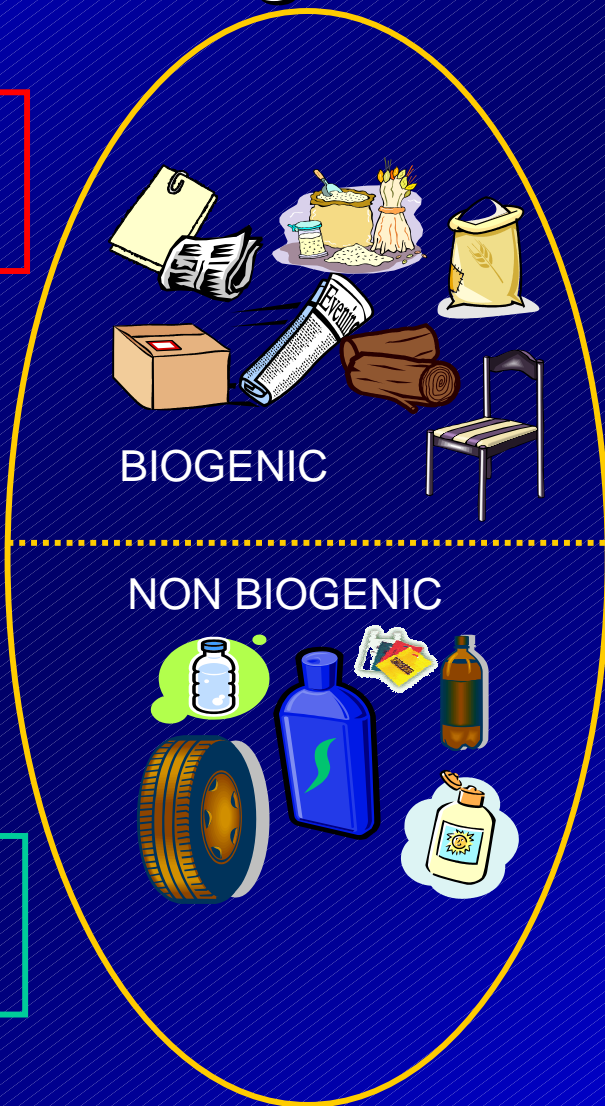

- Energy recovery
- Materials consumption

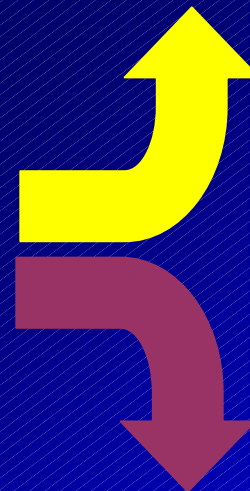

- Energy consumption
- Materials recovery



Analytical fuel characterisation

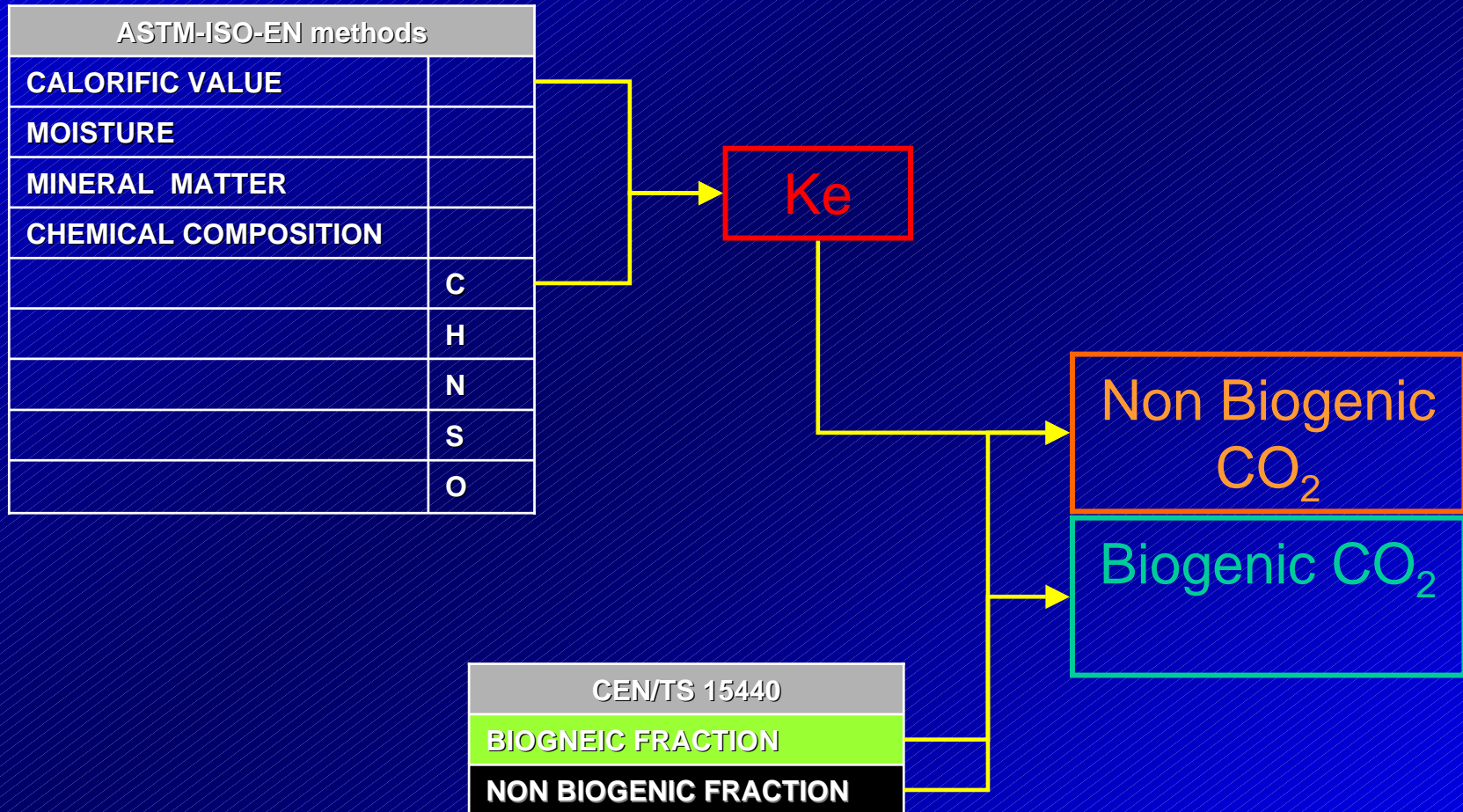



Average properties of different fuels

SSC original data

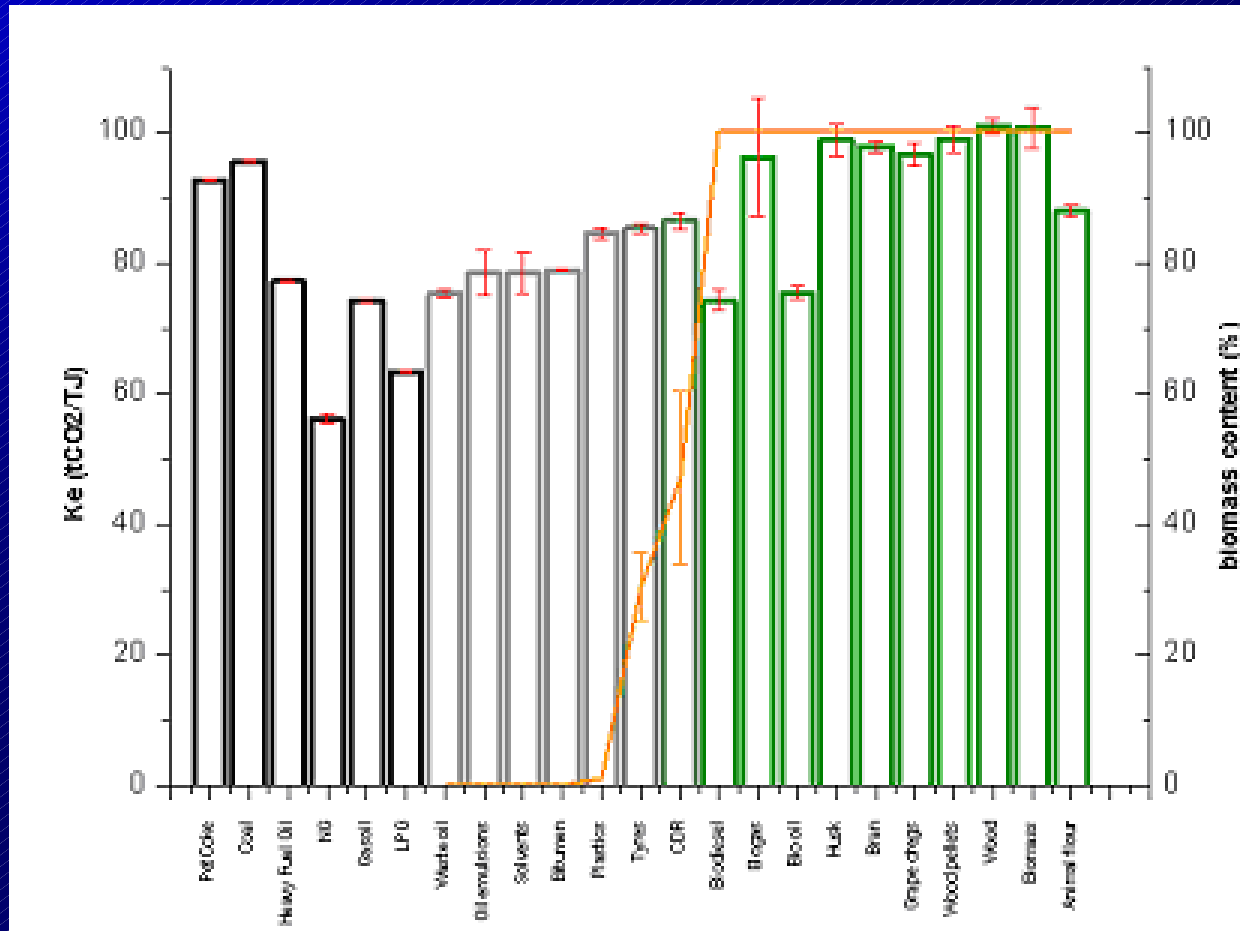



Secondary fuels in the industrial sectors

APAT, ONR (2005), "Rapporto Rifiuti 2005"

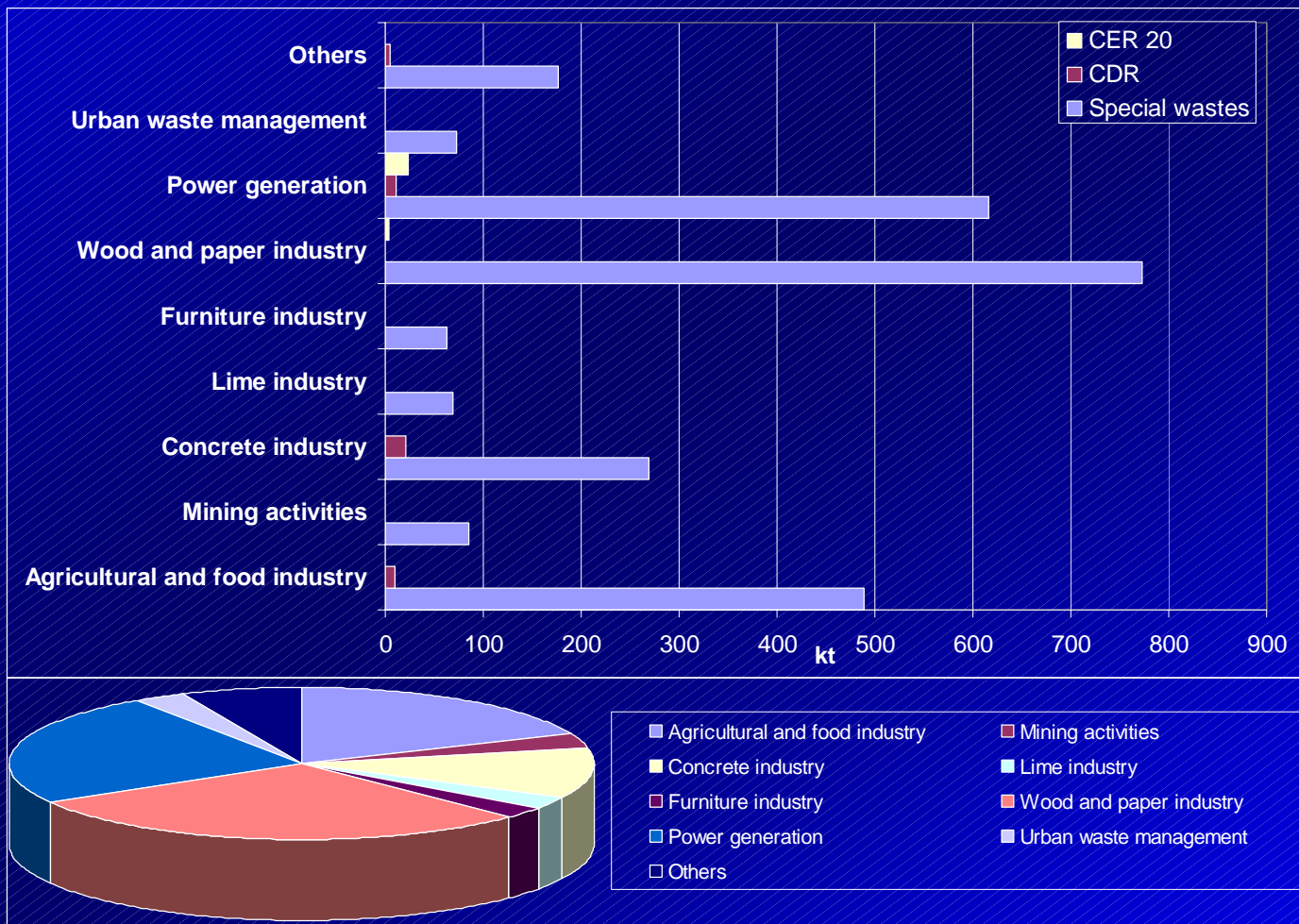



Contribution of secondary fuels

APAT, ONR (2005), "Rapporto Rifiuti 2005"

Amounts of waste by type

2.7 Mt

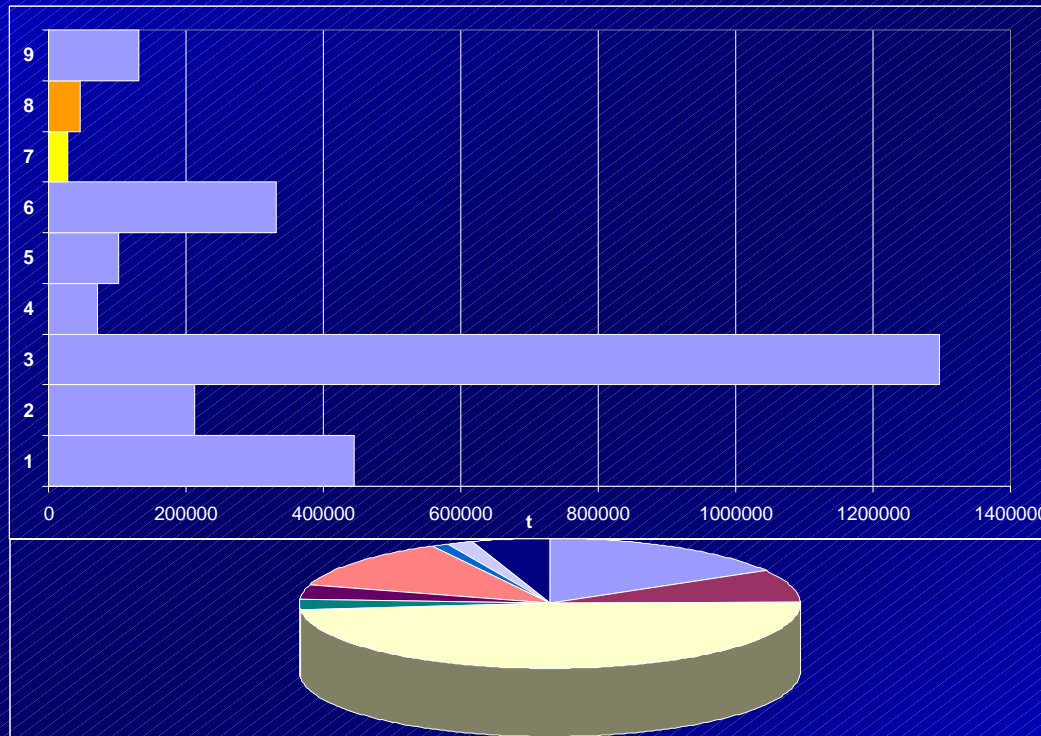

- | | | | |
|---|---|---|--------------------|
| 1 | Agricultural and food industry residues | 6 | Biogas |
| 2 | Alcoholic and non alcoholic beverages production residues | 7 | Urban solid wastes |
| 3 | Wood and paper industry residues | 8 | CDR |
| 4 | Waste oils | 9 | Others |
| 5 | Tyres | | |



Contribution of secondary fuels

APAT, ONR (2005), "Rapporto Rifiuti 2005"

Amounts of energy

50000 TJ

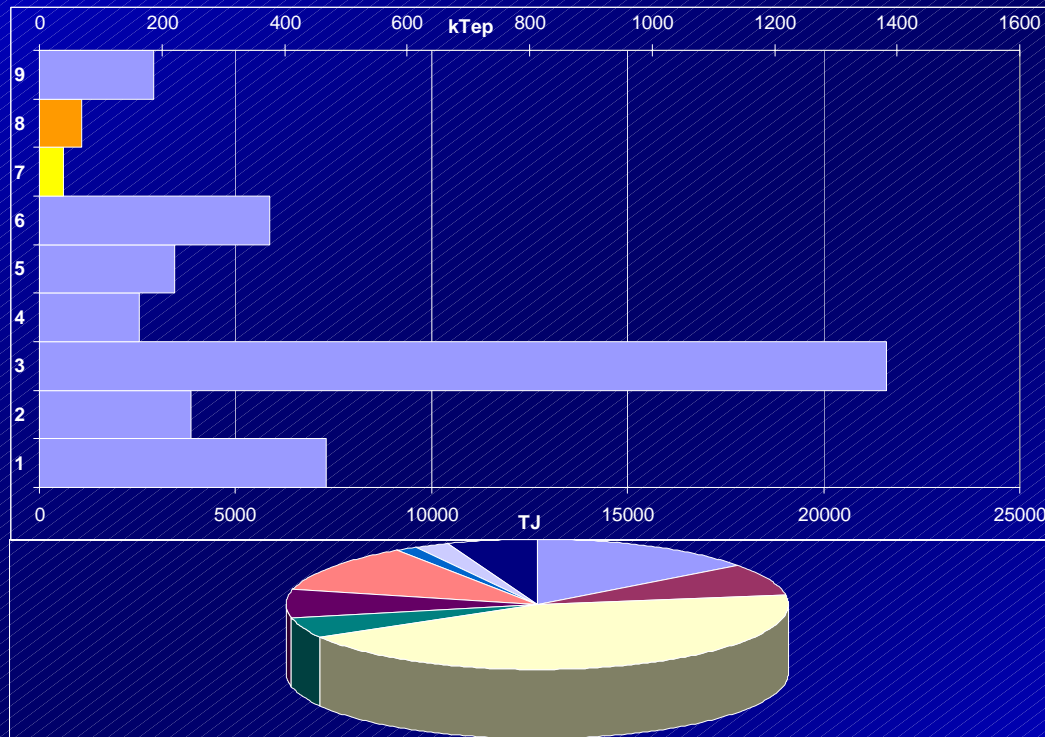

- | | | | |
|---|---|---|--------------------|
| 1 | Agricultural and food industry residues | 6 | Biogas |
| 2 | Alcoholic and non alcoholic beverages production residues | 7 | Urban solid wastes |
| 3 | Wood and paper industry residues | 8 | CDR |
| 4 | Waste oils | 9 | Others |
| 5 | Tyres | | |



Contribution of secondary fuels

APAT, ONR (2005), "Rapporto Rifiuti 2005"

Amounts of total CO2

4.7 Mt

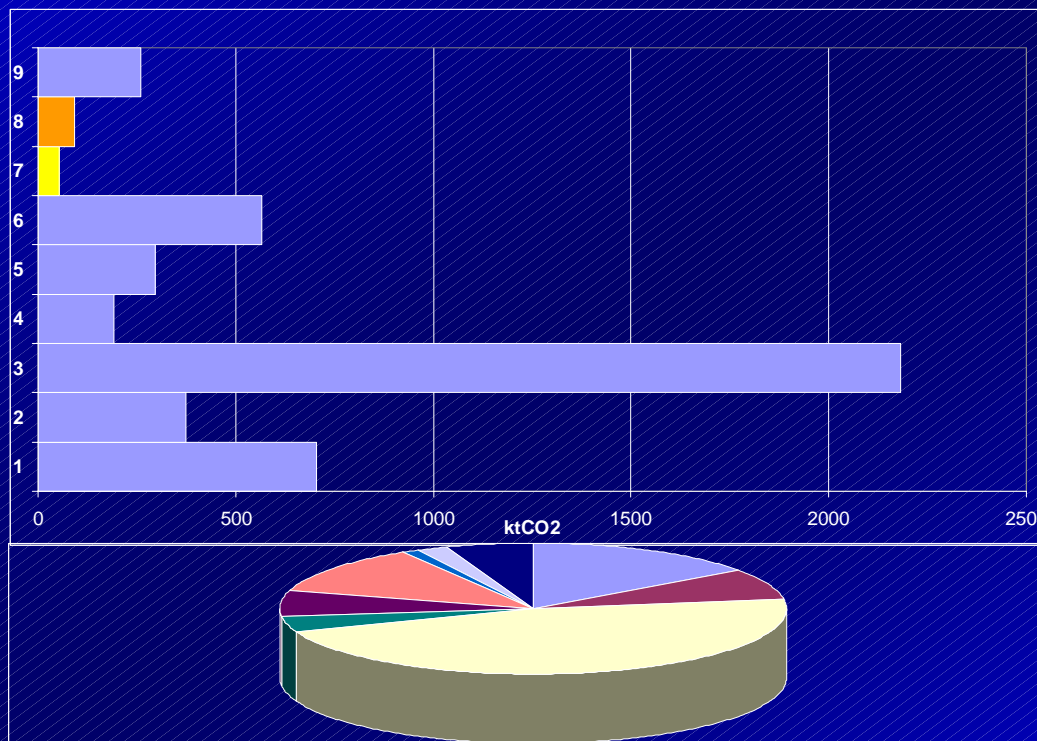

- | | | | |
|---|---|---|--------------------|
| 1 | Agricultural and food industry residues | 6 | Biogas |
| 2 | Alcoholic and non alcoholic beverages production residues | 7 | Urban solid wastes |
| 3 | Wood and paper industry residues | 8 | CDR |
| 4 | Waste oils | 9 | Others |
| 5 | Tyres | | |



Contribution of secondary fuels

APAT, ONR (2005), "Rapporto Rifiuti 2005"

Amounts of non biogenic CO2

0.6 Mt

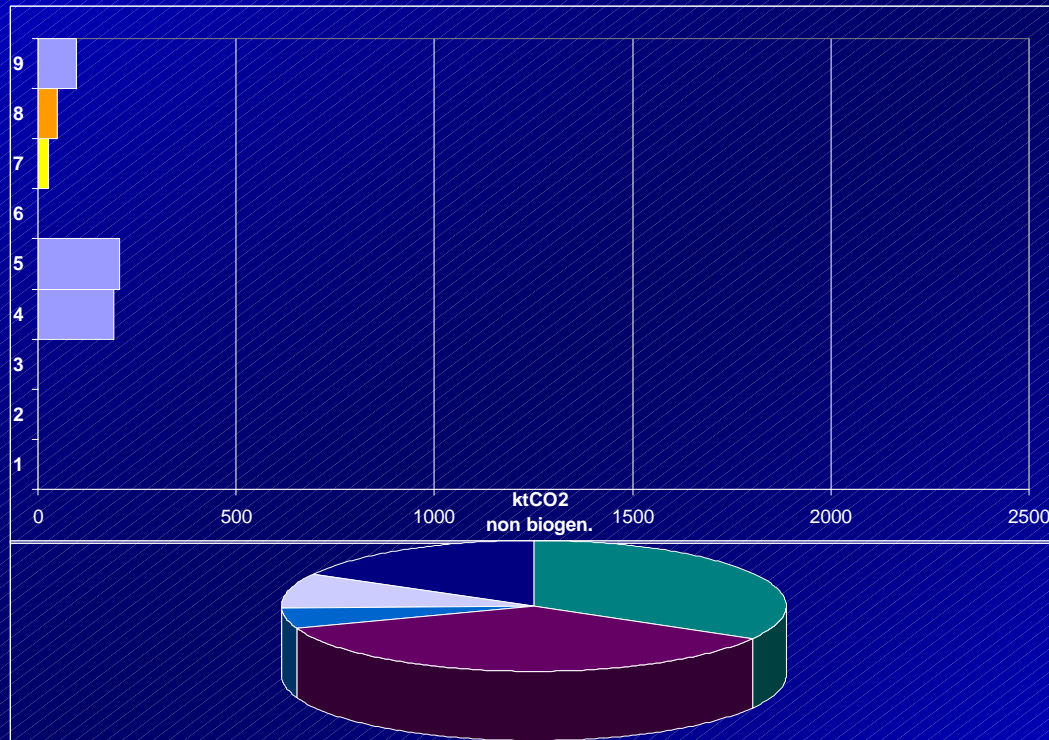

- | | | | |
|---|---|---|--------------------|
| 1 | Agricultural and food industry residues | 6 | Biogas |
| 2 | Alcoholic and non alcoholic beverages production residues | 7 | Urban solid wastes |
| 3 | Wood and paper industry residues | 8 | CDR |
| 4 | Waste oils | 9 | Others |
| 5 | Tyres | | |



Forecasts for the energy sector

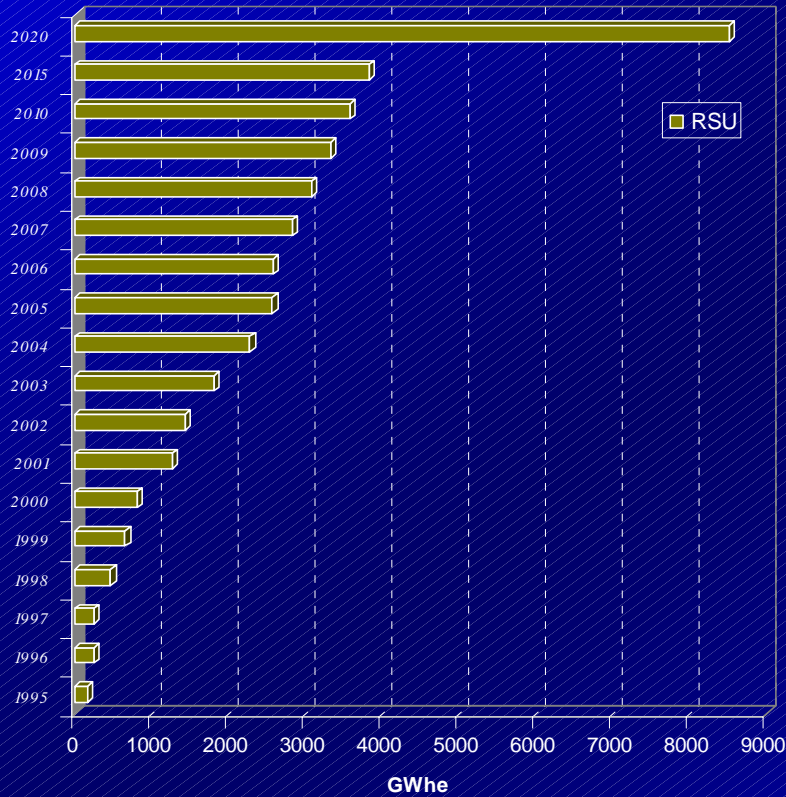

UP forecasts 2006

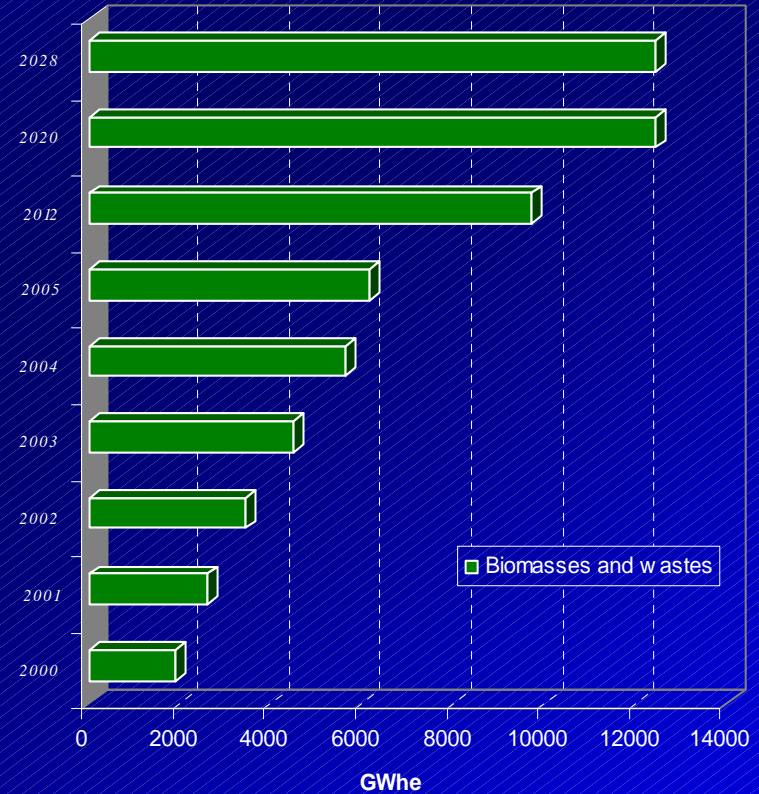

ENEA-APAT forecasts 2006

Technology comparison

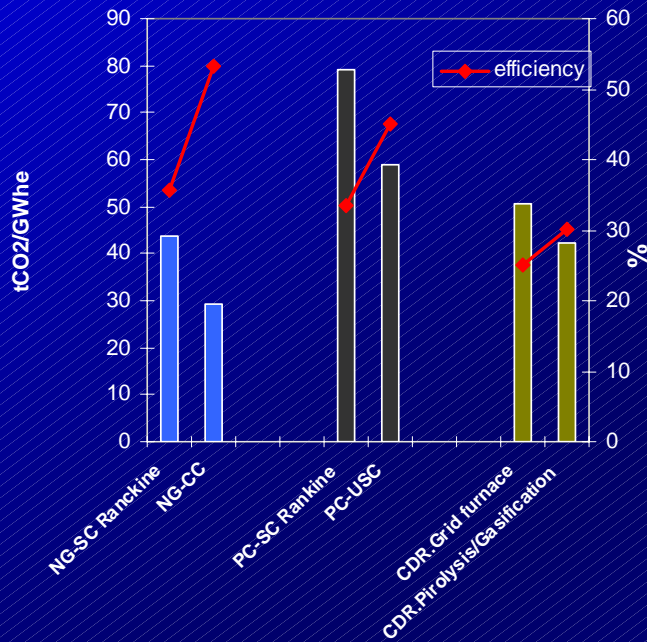

- Importance of technological progress
- CO2 reduction up to 6 Mt
- Cost reduction up to 500 M€/y

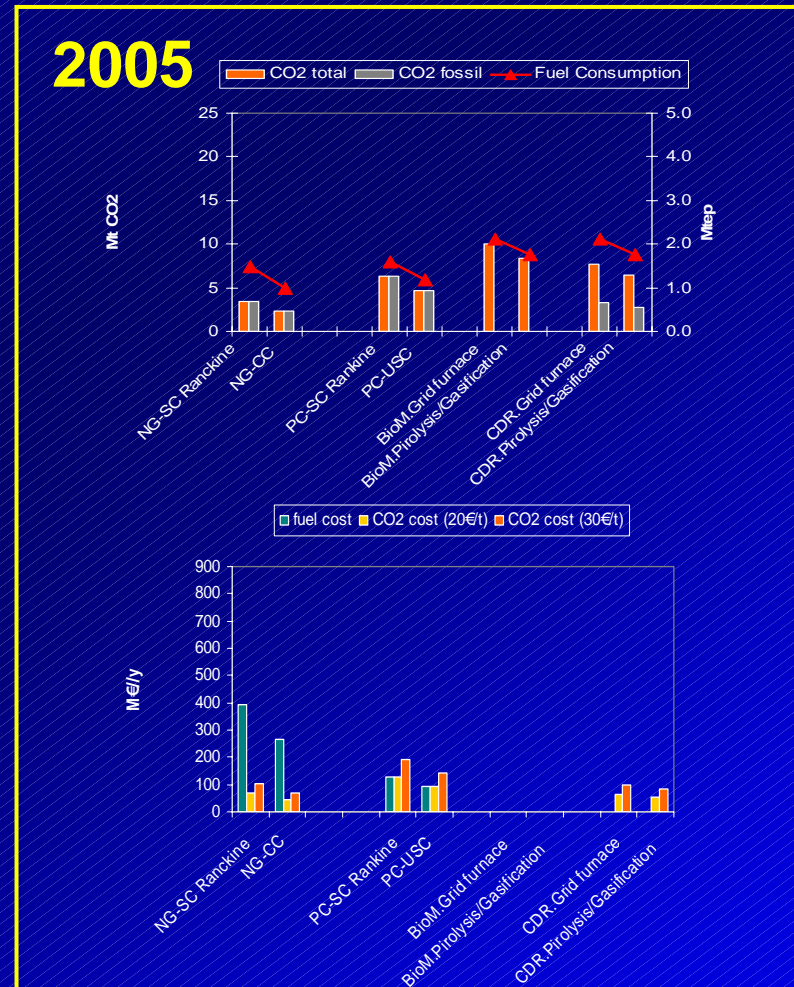

Technology comparison

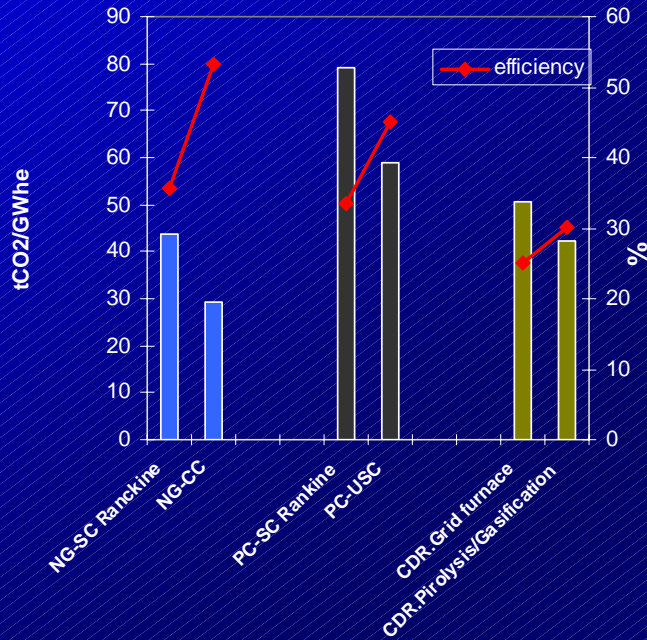

- Importance of technological progress
- CO2 reduction up to 13 Mt
- Cost reduction up to 1000M€/y

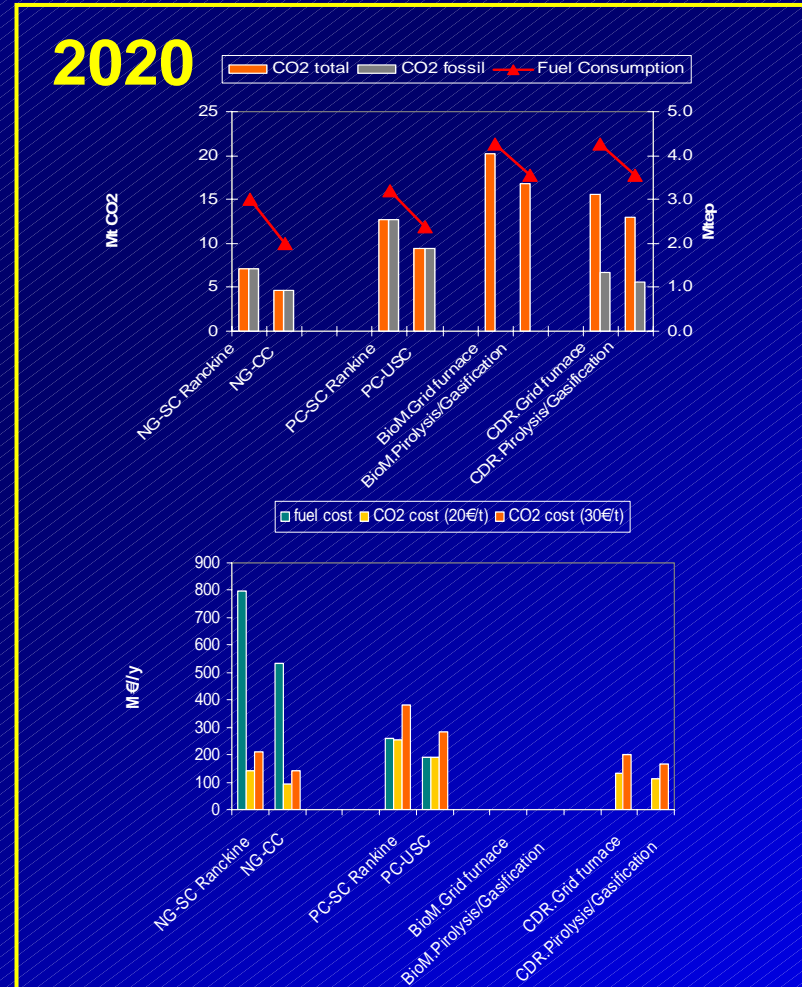

Conclusions

- The contribution of secondary fuels, despite its actual small input to the overall energy system, can play a not negligible role in the present situation and is destined to increase its importance in the future scenarios
- The operating period of a biomass combustion plant could be planned according to the energy demand, in a easier way in respect to other non combustible renewable sources
- Technological development emerges as a fundamental factor in the energetic strategies